

WELCOME TO

Understanding Electrical Troubleshooting on Refrigeration Systems

LET'S GET A CONVERSATION GOING.





REFRIGERATION
MENTOR

Refrigeration Electrical Troubleshooting

How to stop guessing and start proving



Most electrical issues are misdiagnosed





Parts Changing Is Not Troubleshooting

Guessing costs time, money, and confidence





Find where voltage disappears

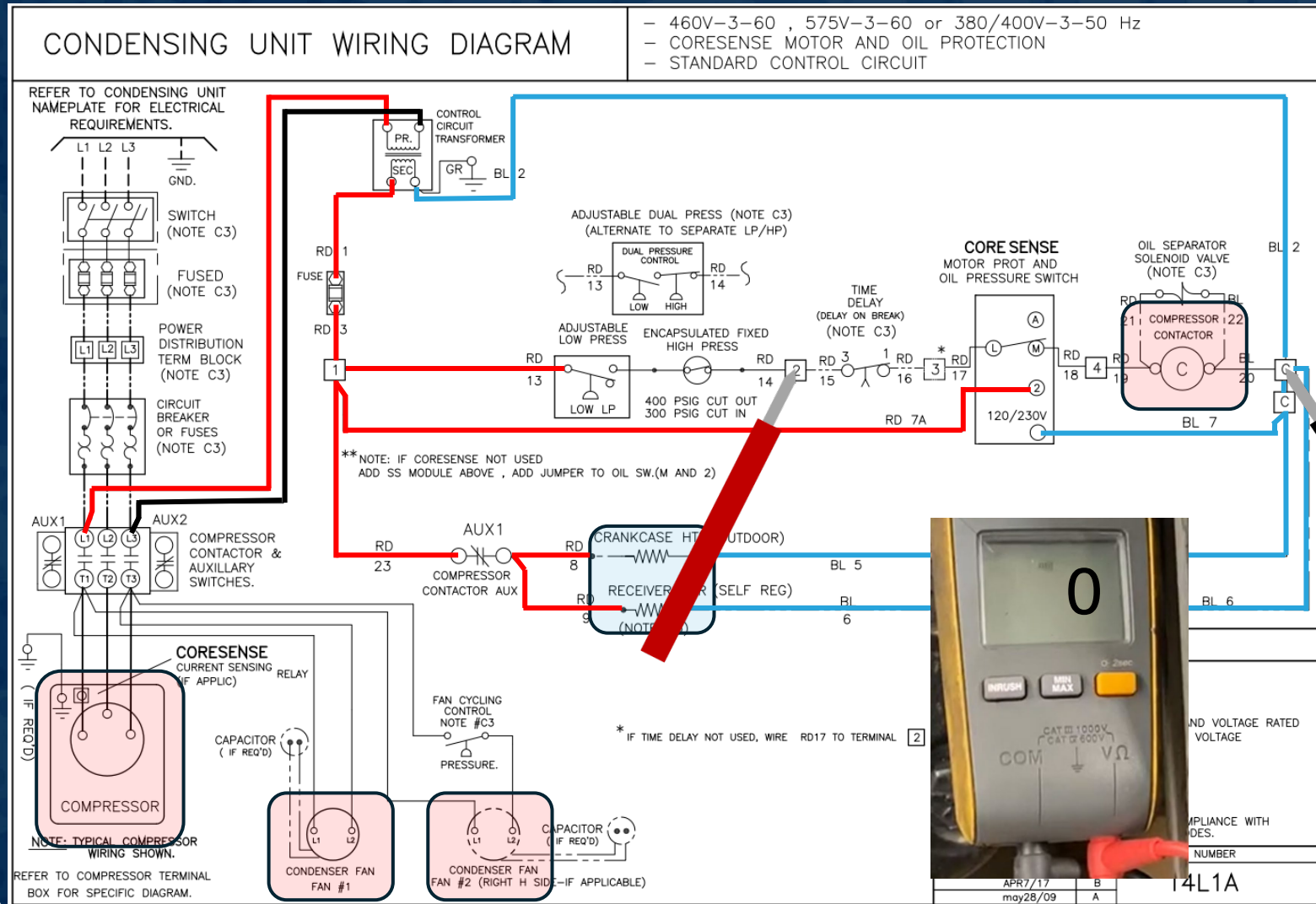

Power circuits and control circuits

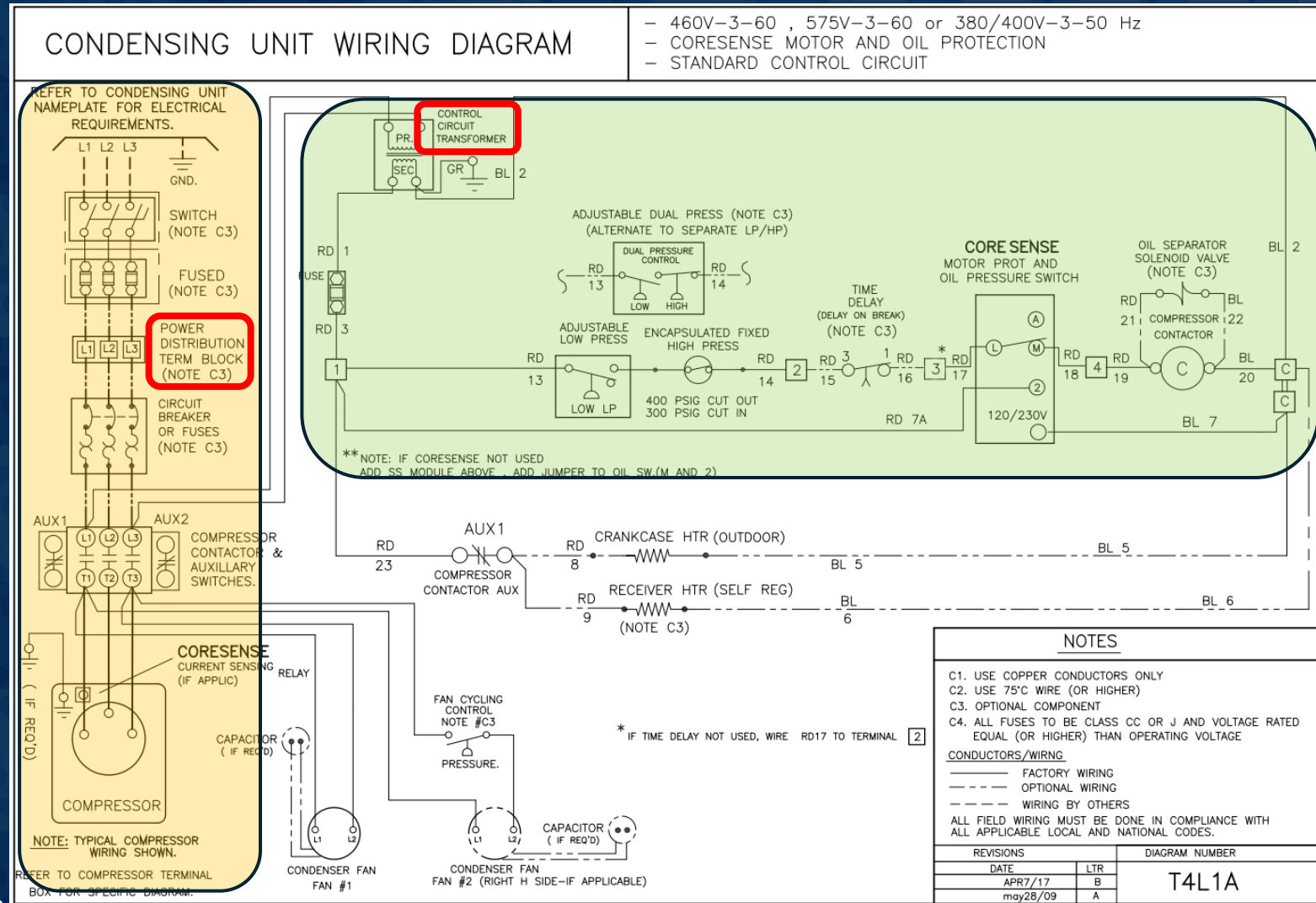



They allow or block power

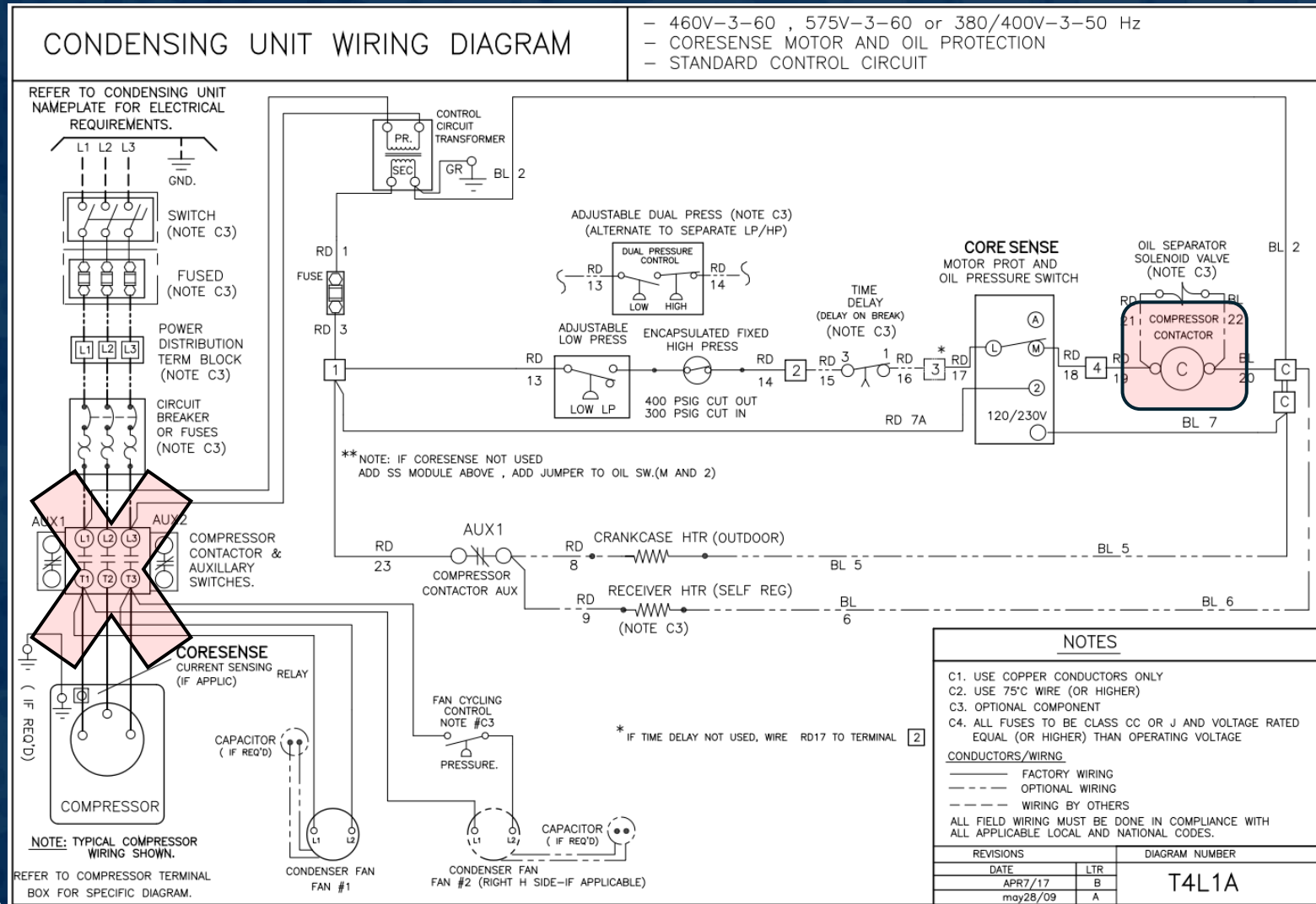



One open stops everything

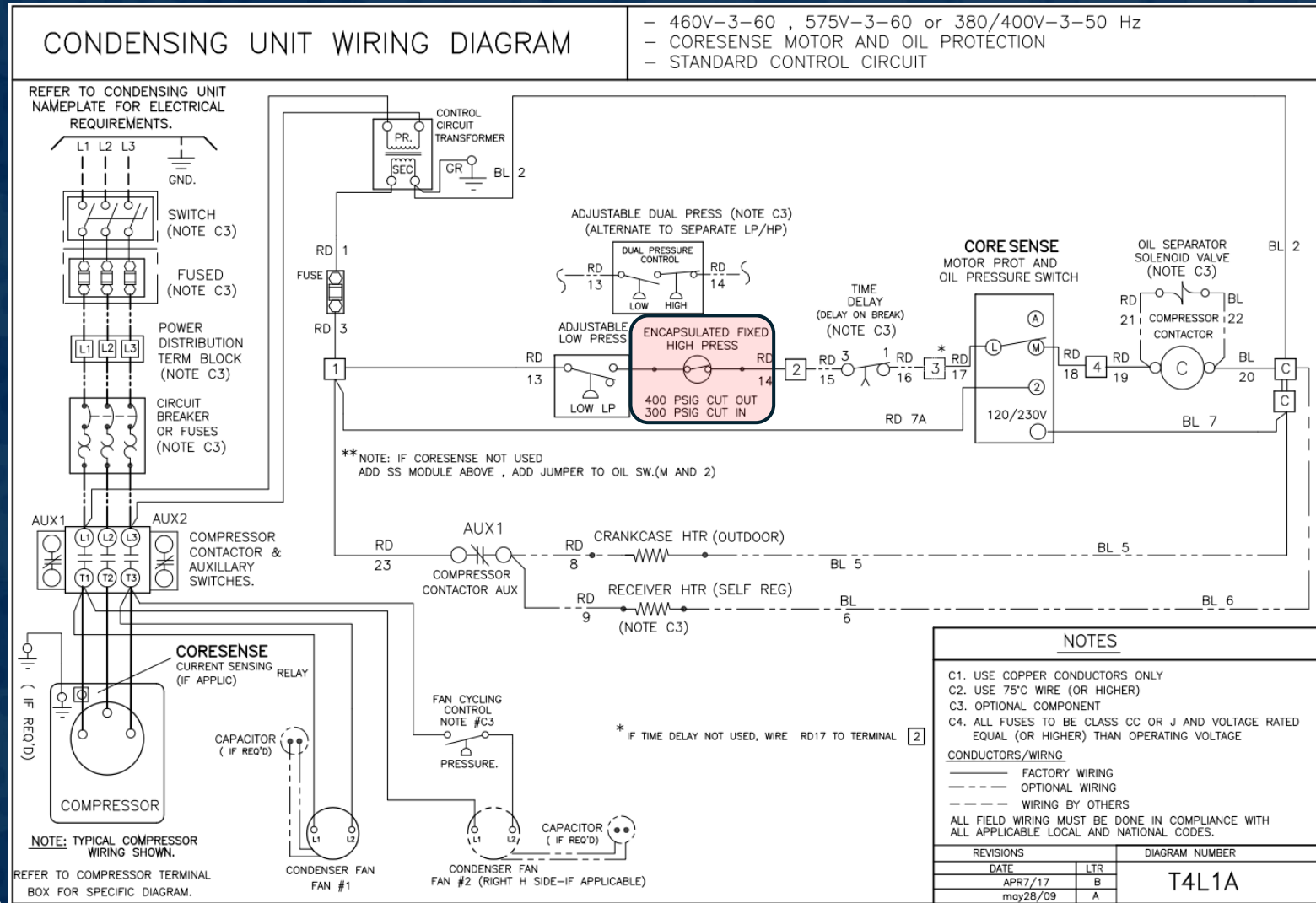



Loads can run independently

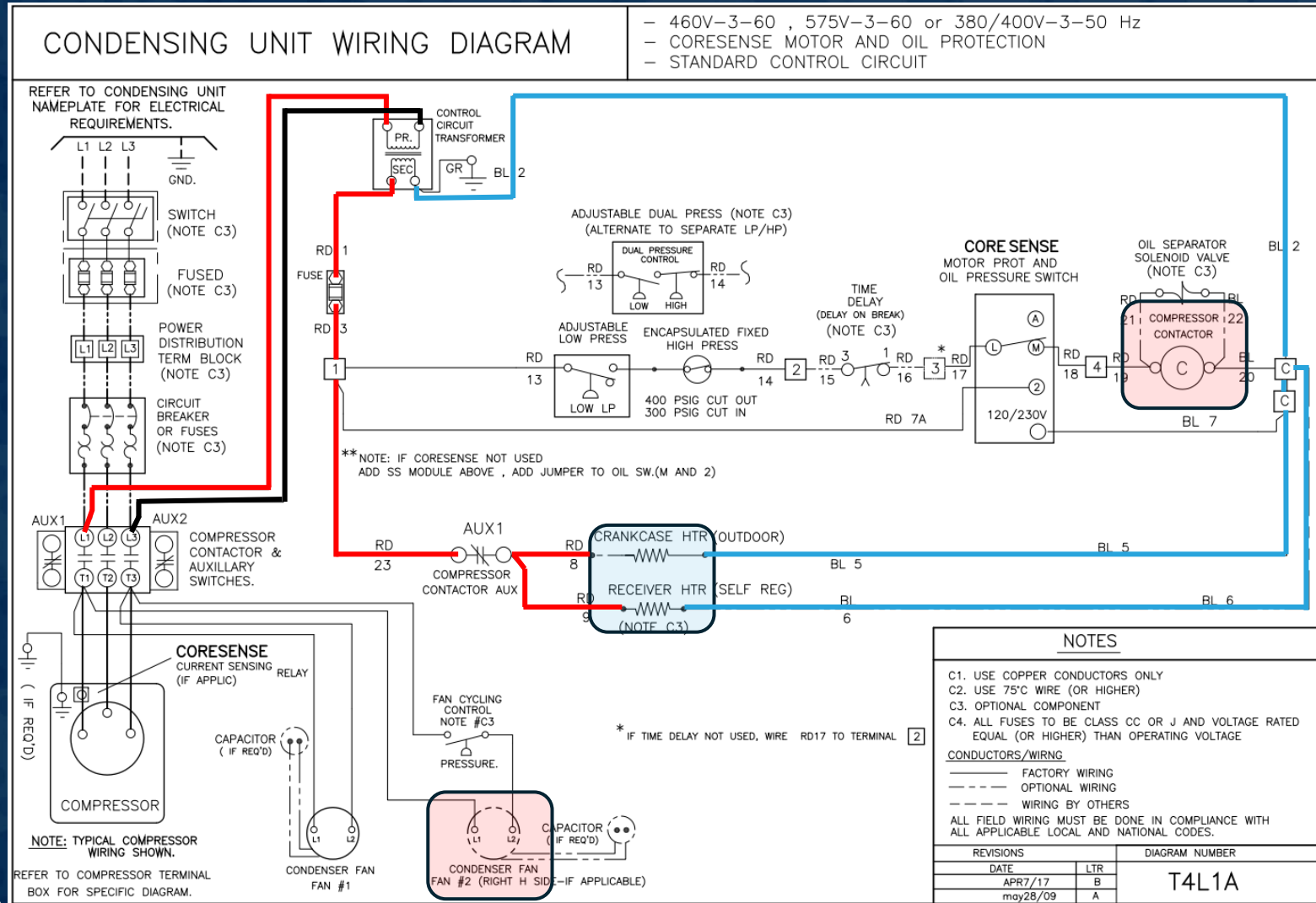

What a Diagram Really Shows

Logic, not physical layout

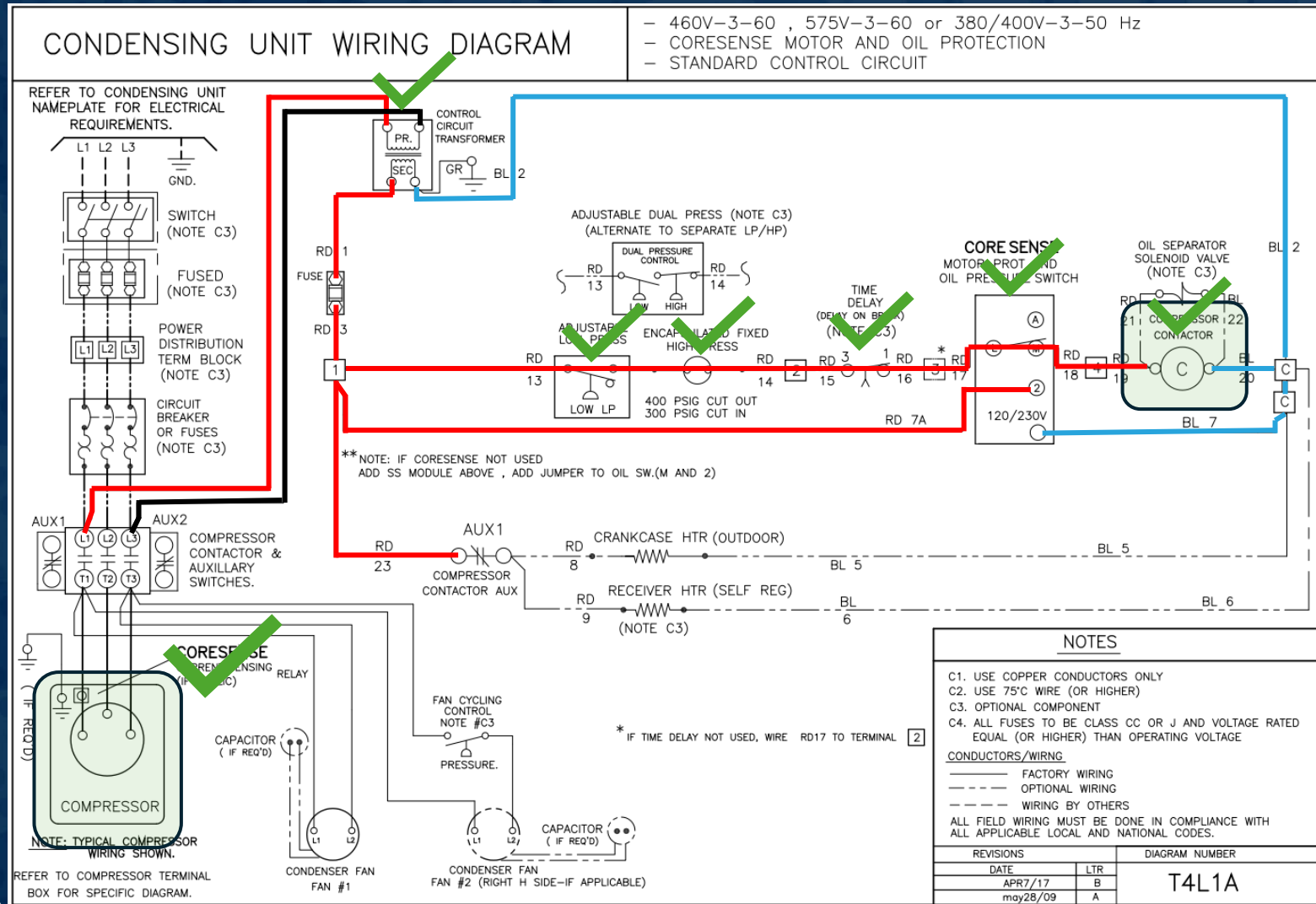



REFRIGERATION MENTOR Every Electrical Problem Fits One Bucket

No power, blocked power, failed load

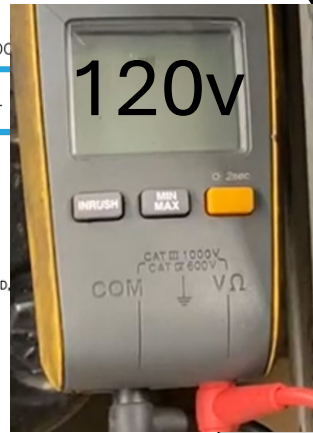
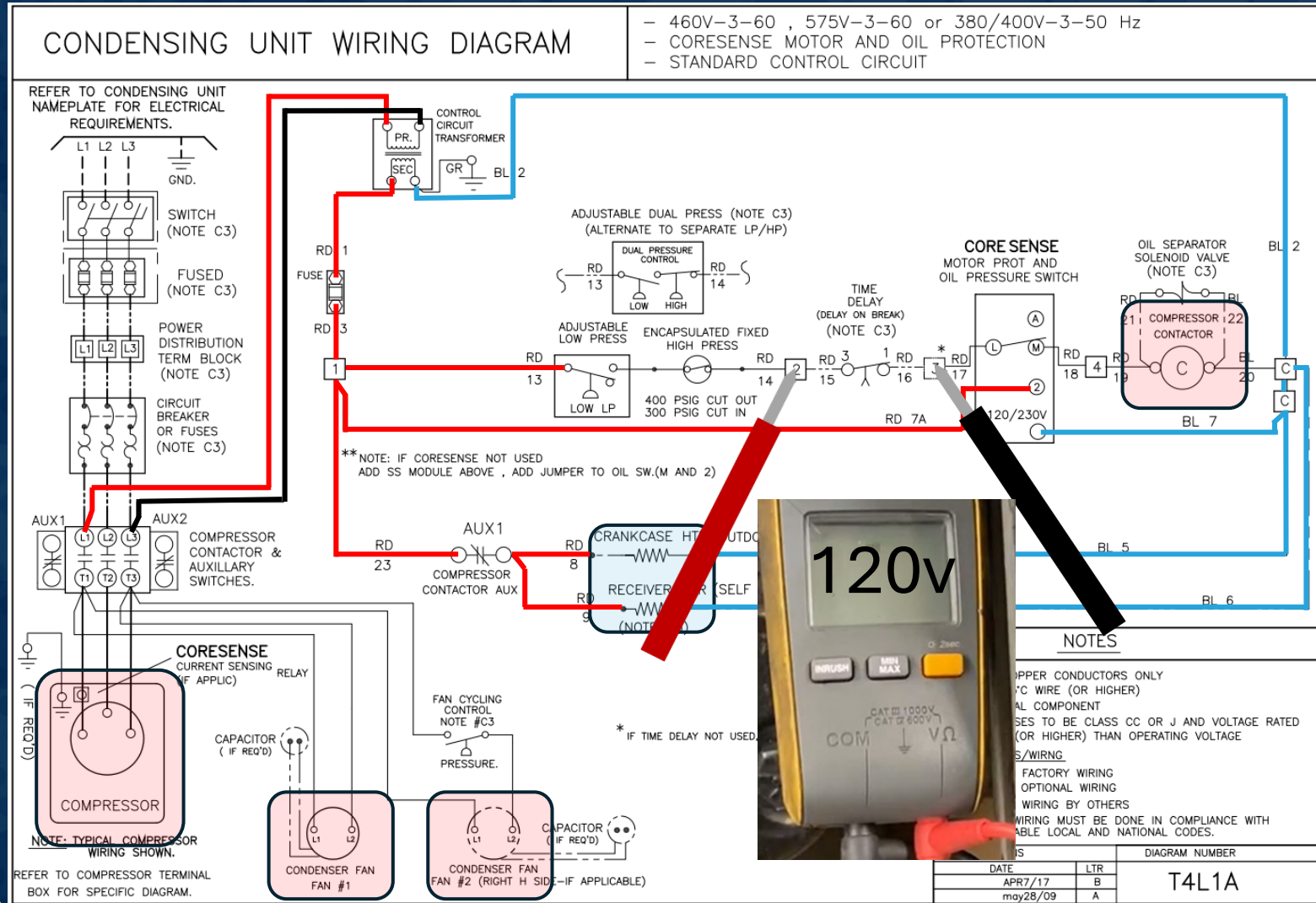

Ground lies

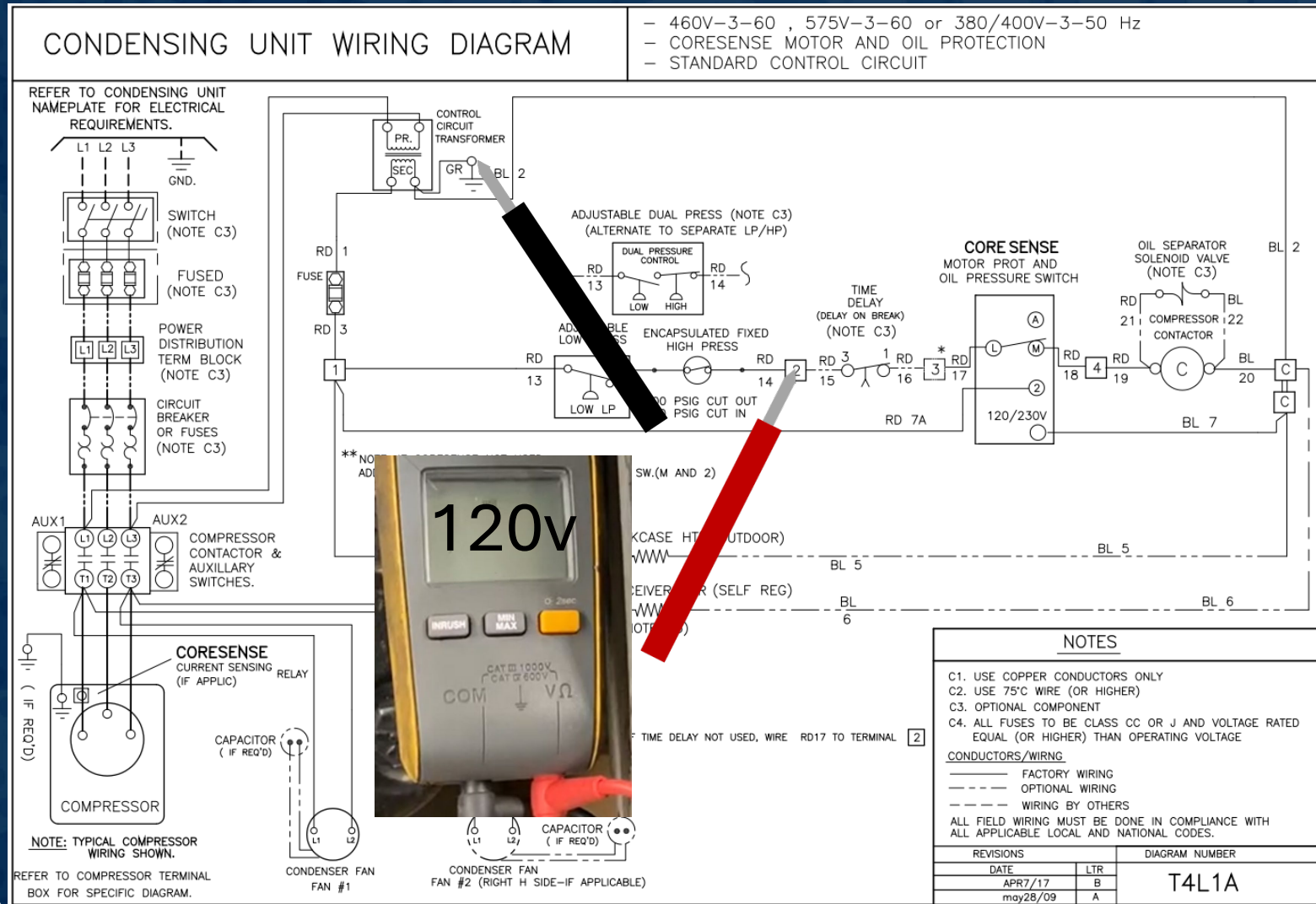

Measure across the component

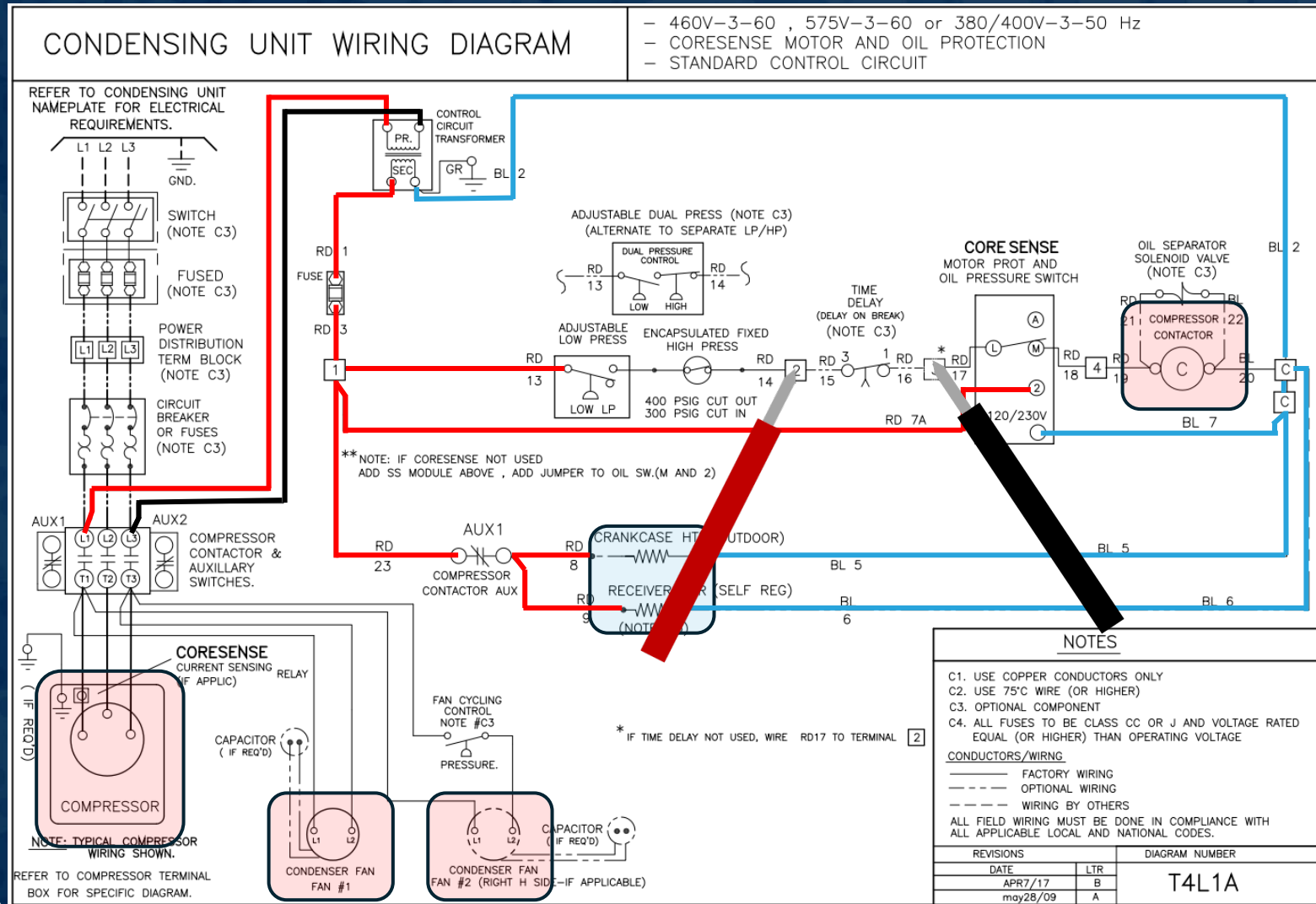

Zero volts across it

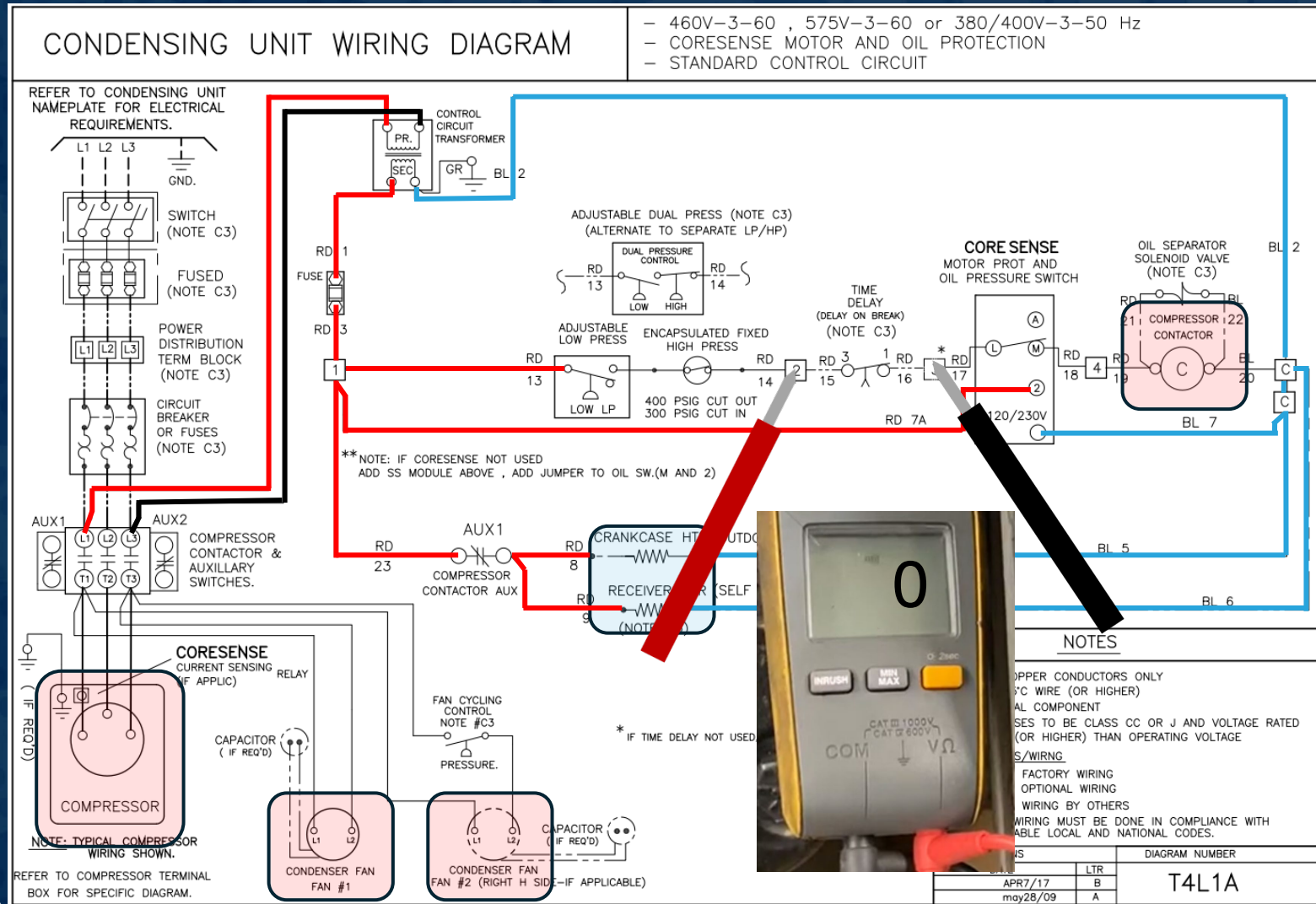



Voltage appears across it

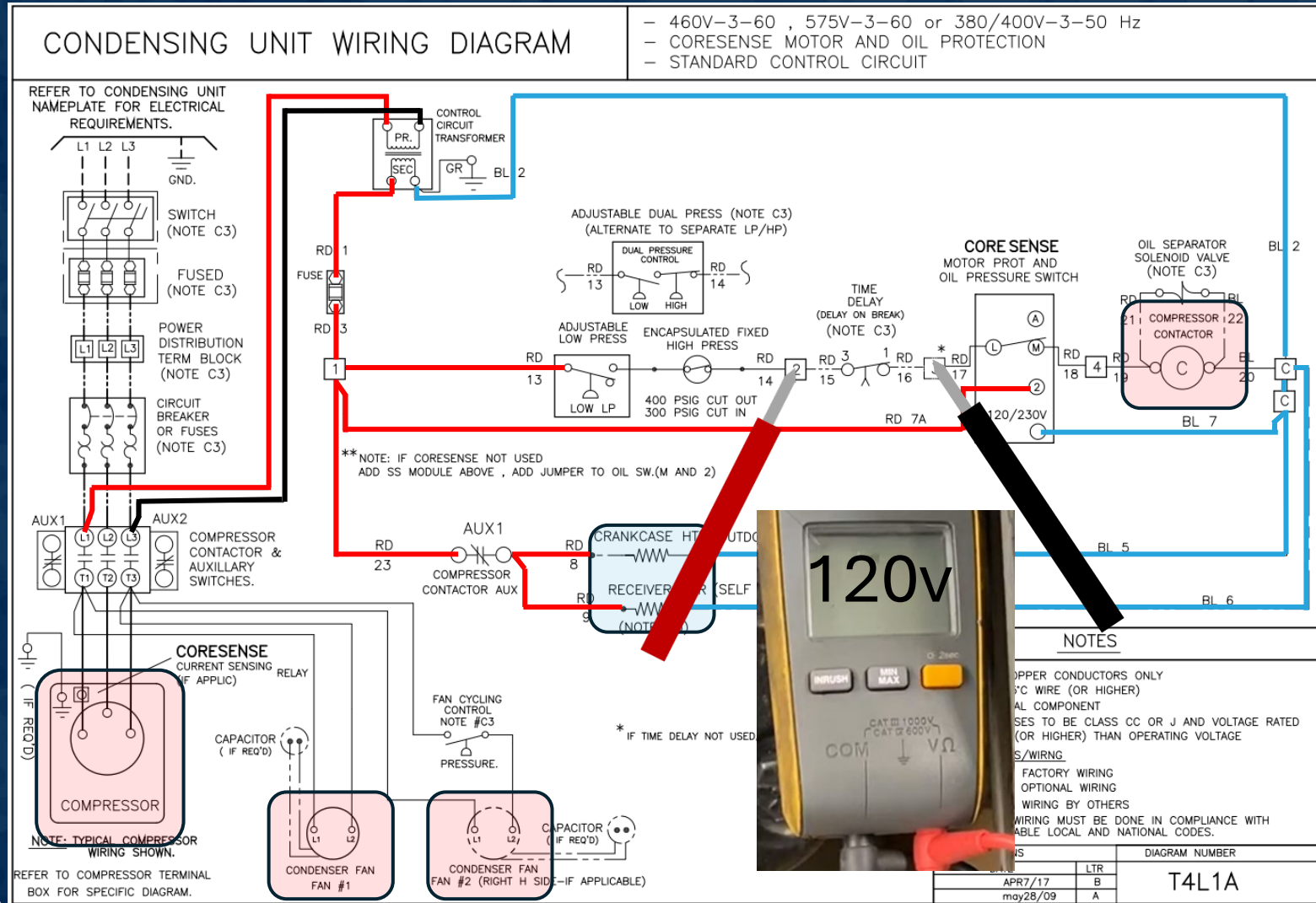

Especially on contactors

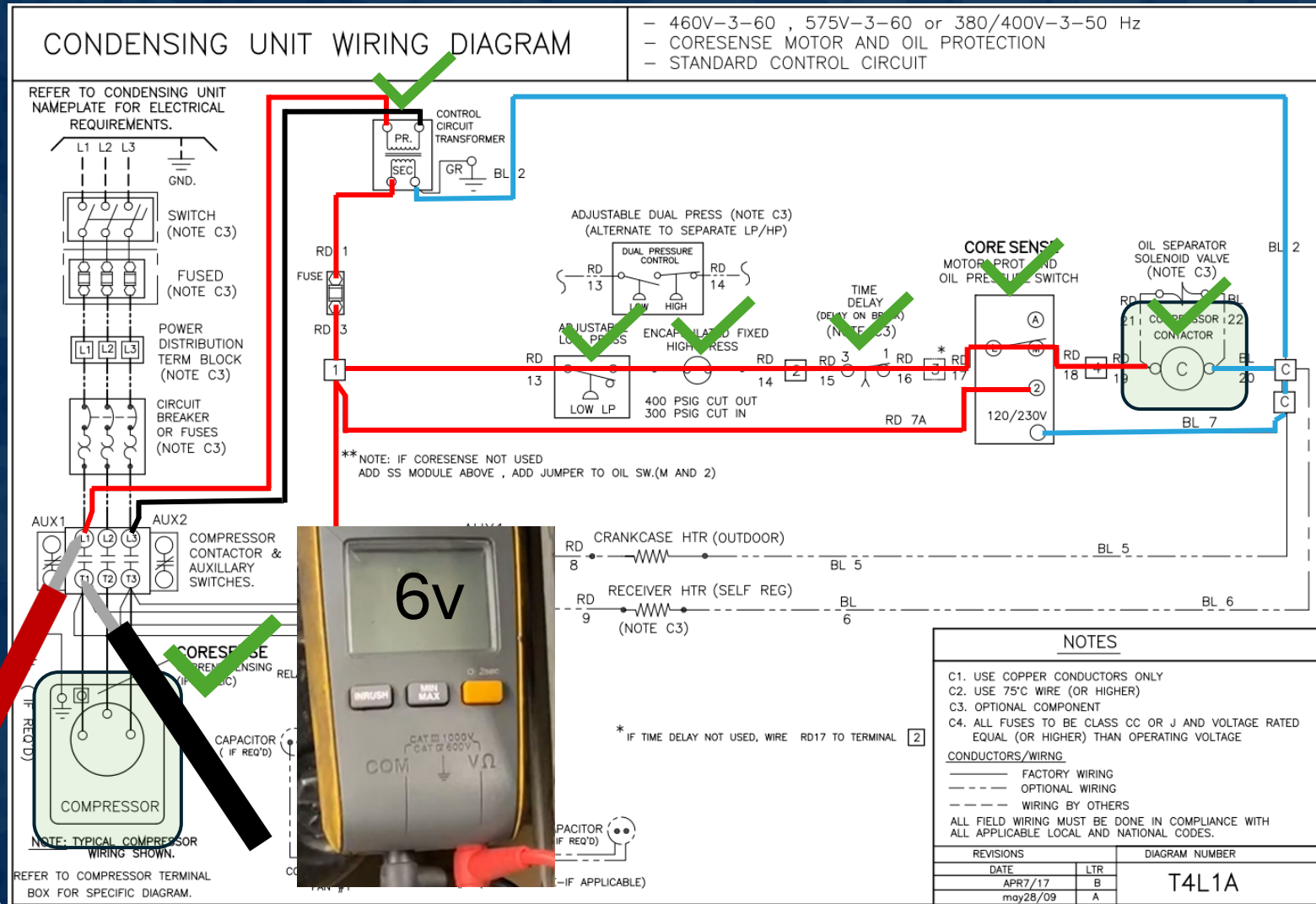



Coil Pulled In, Load Dead

Where did voltage stop?

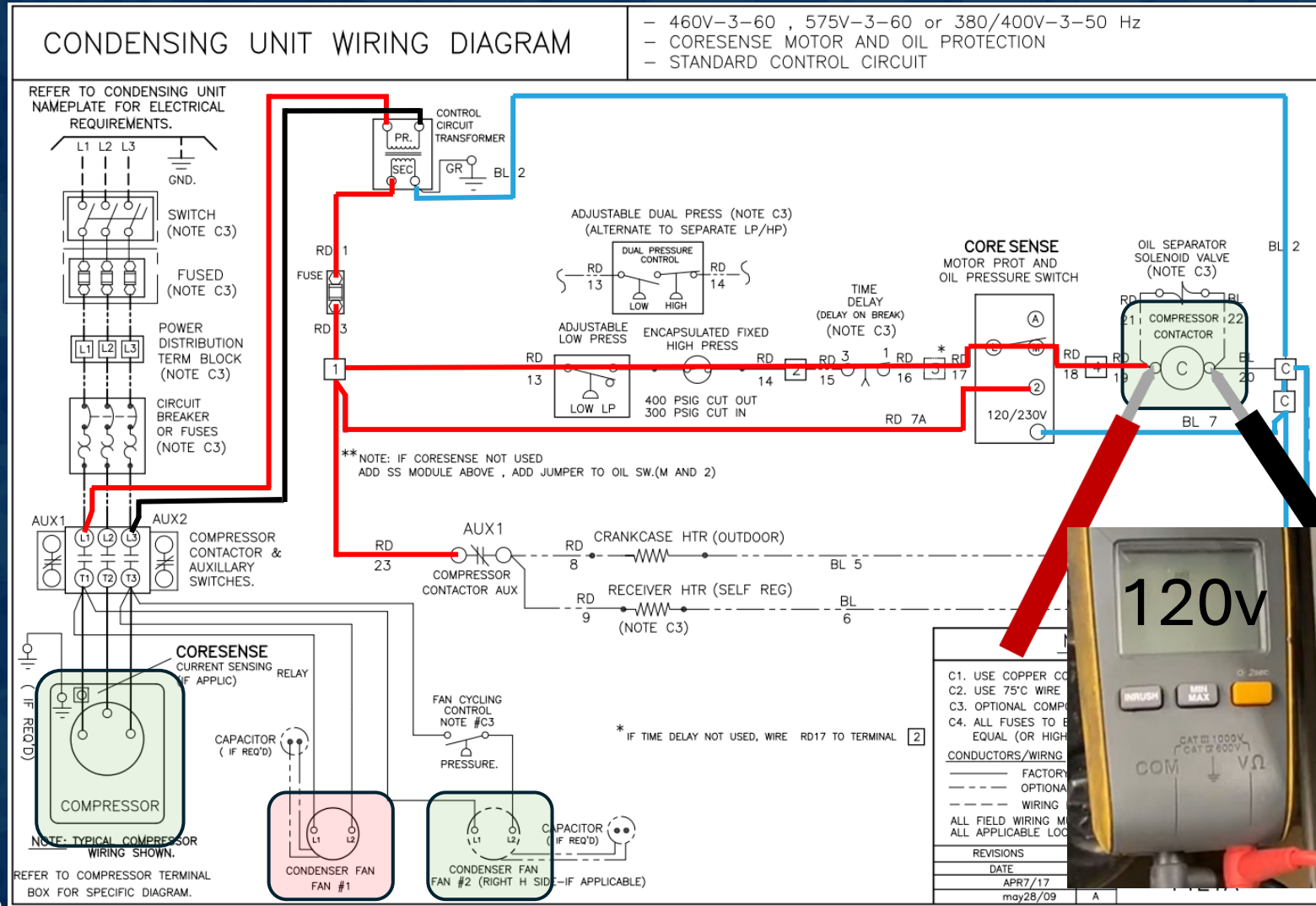
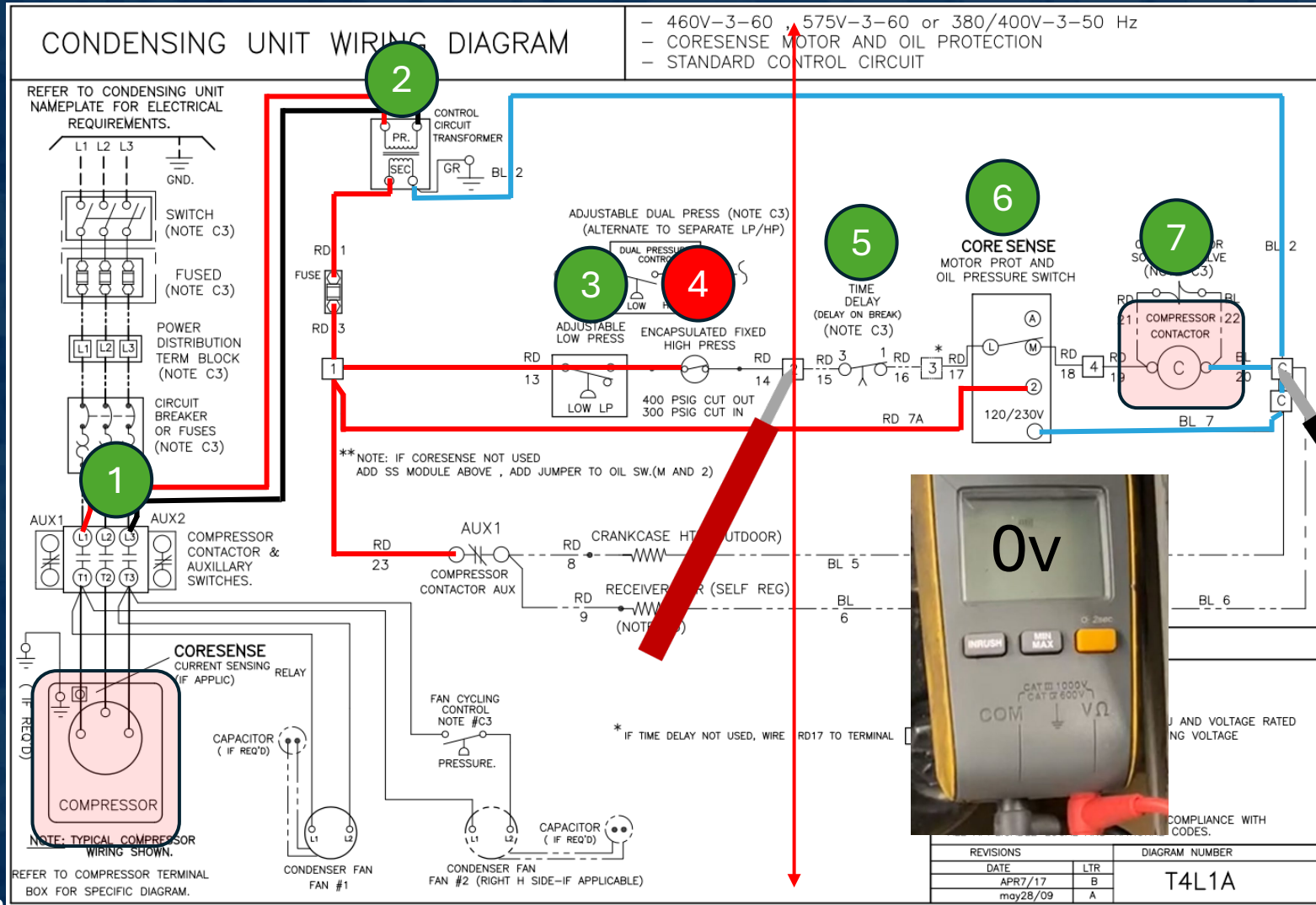

Diagram Courtesy of Keeprite



Check halfway first



COMPLIANCE WITH CODES.



Why Techs Miss This

They check presence, not loss

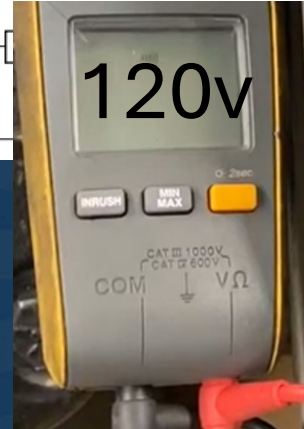
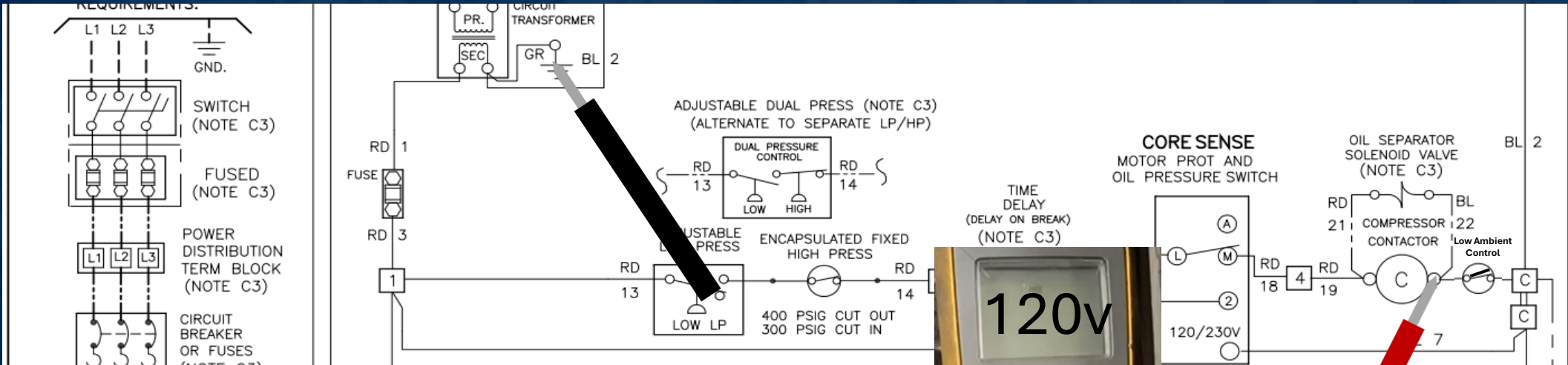

Real Condensing Unit Diagram

Looks complex, follows simple rules

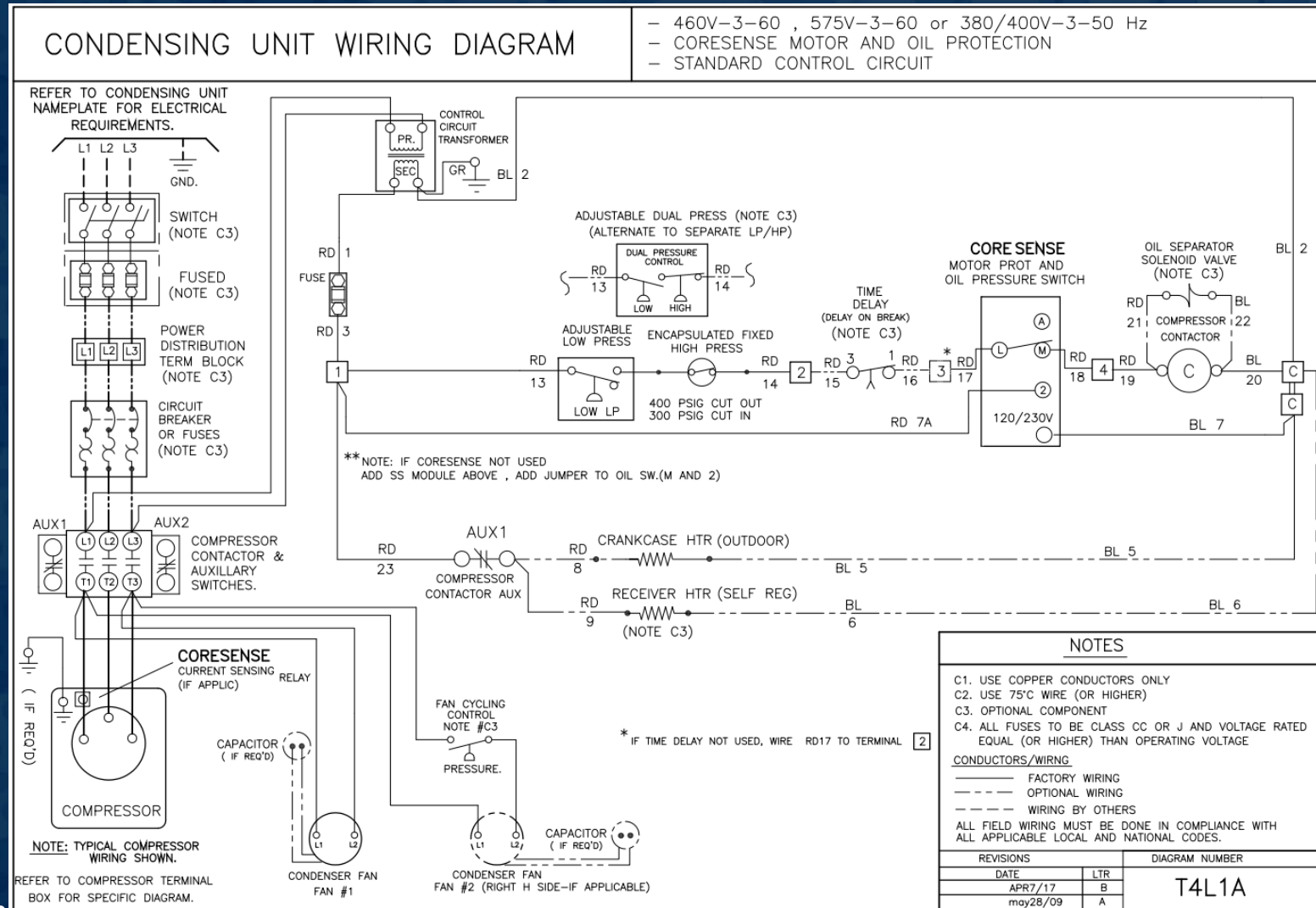



Ignore everything else

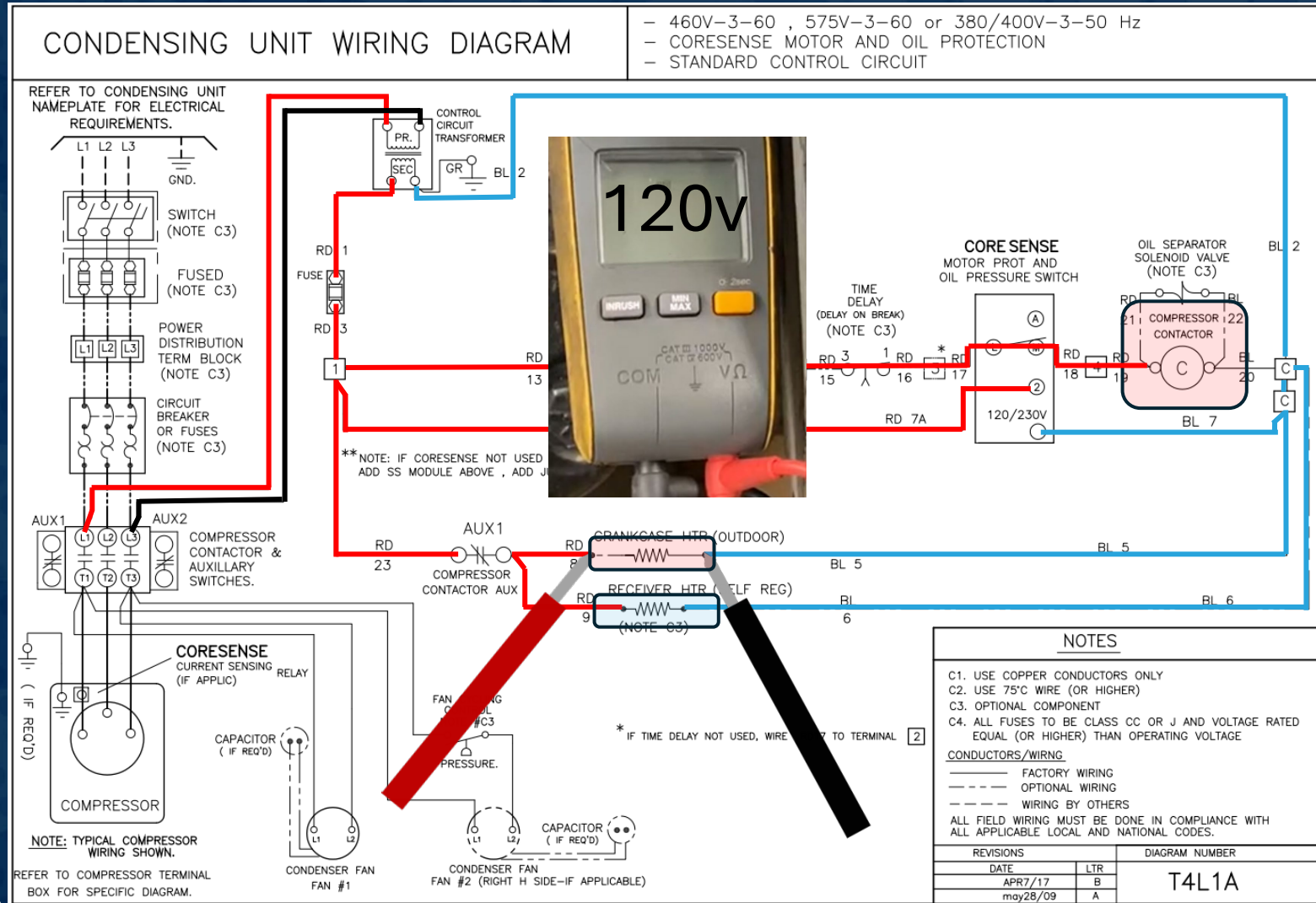

Control voltage origin

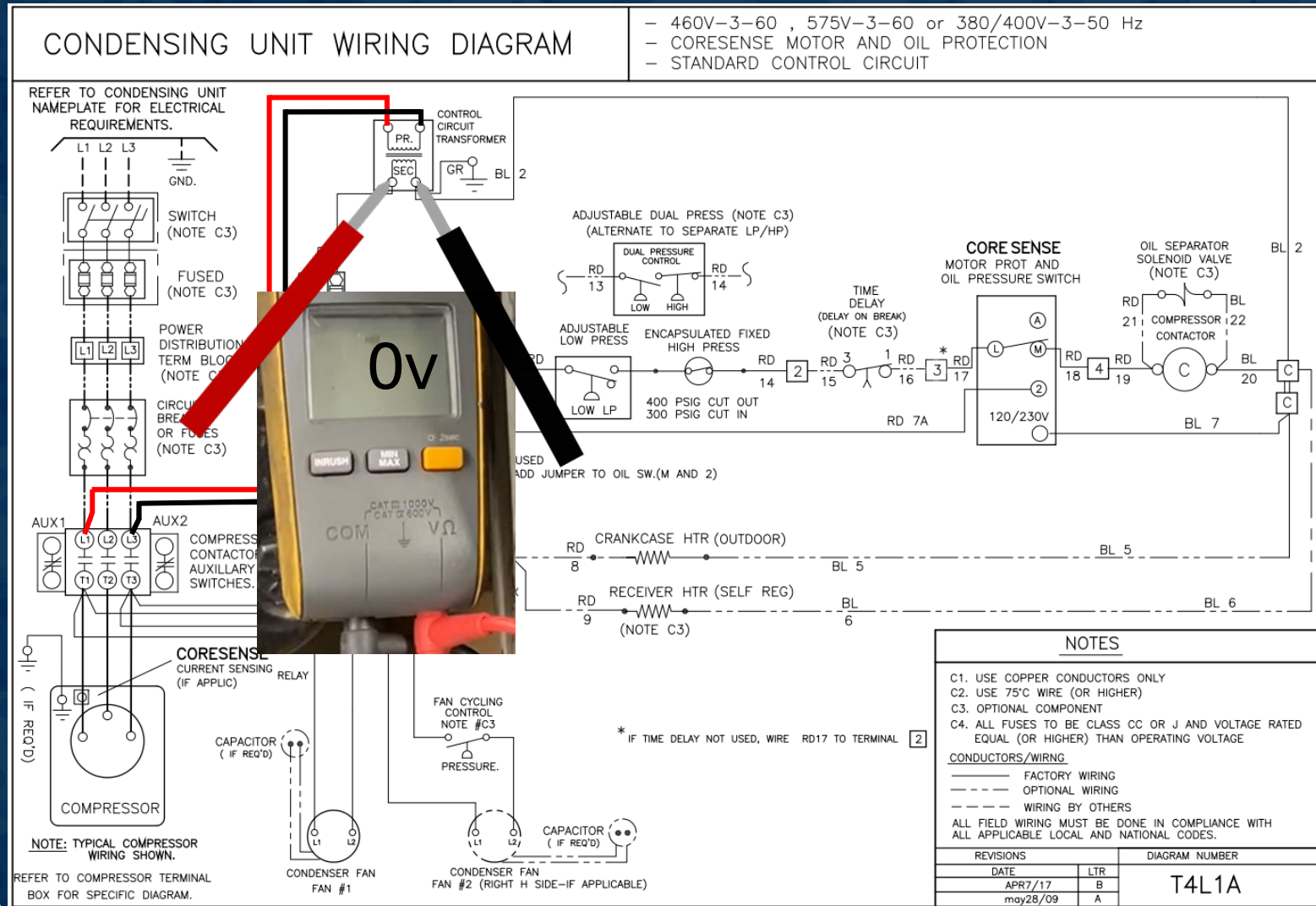



Open on drop

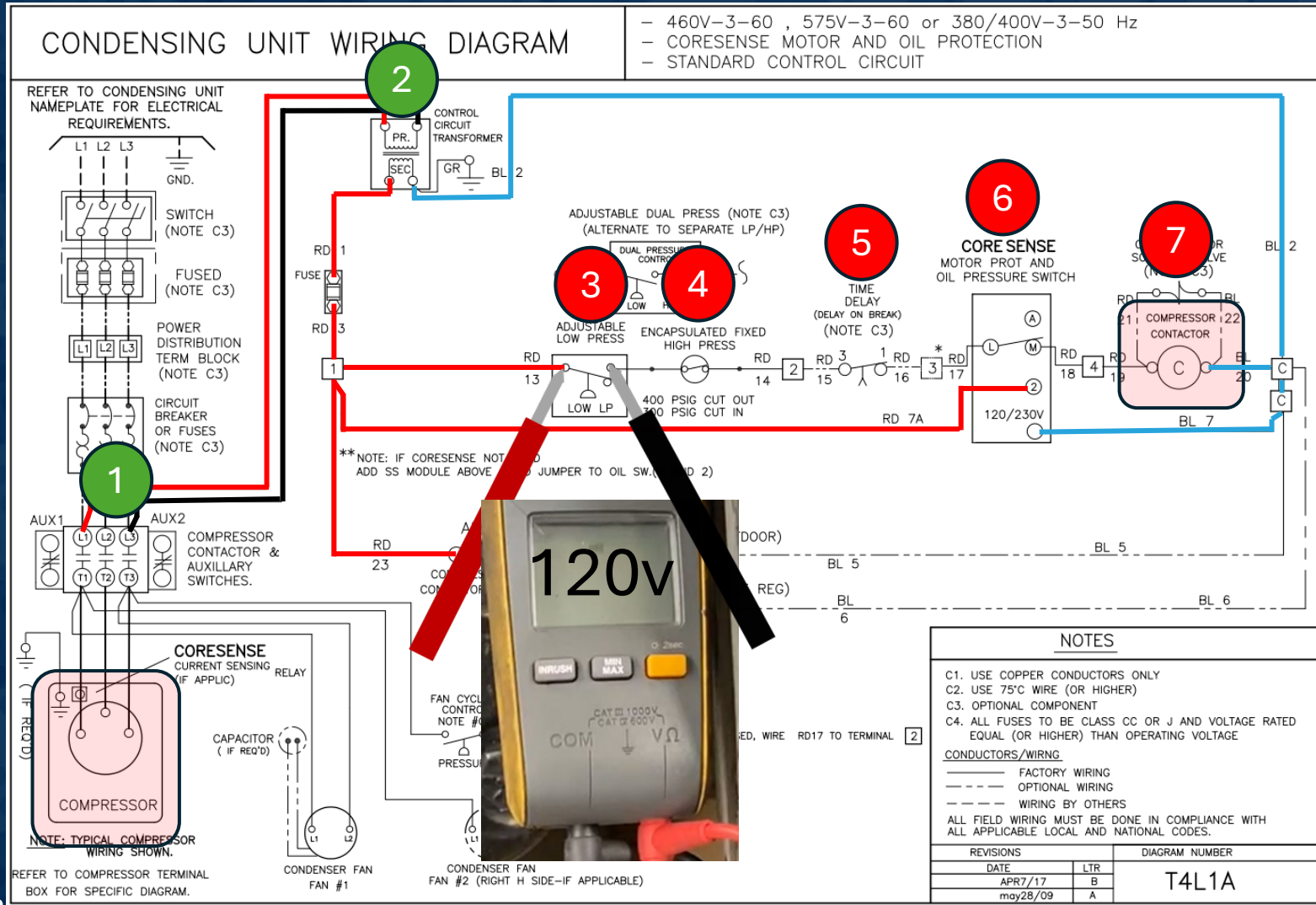

Open on rise

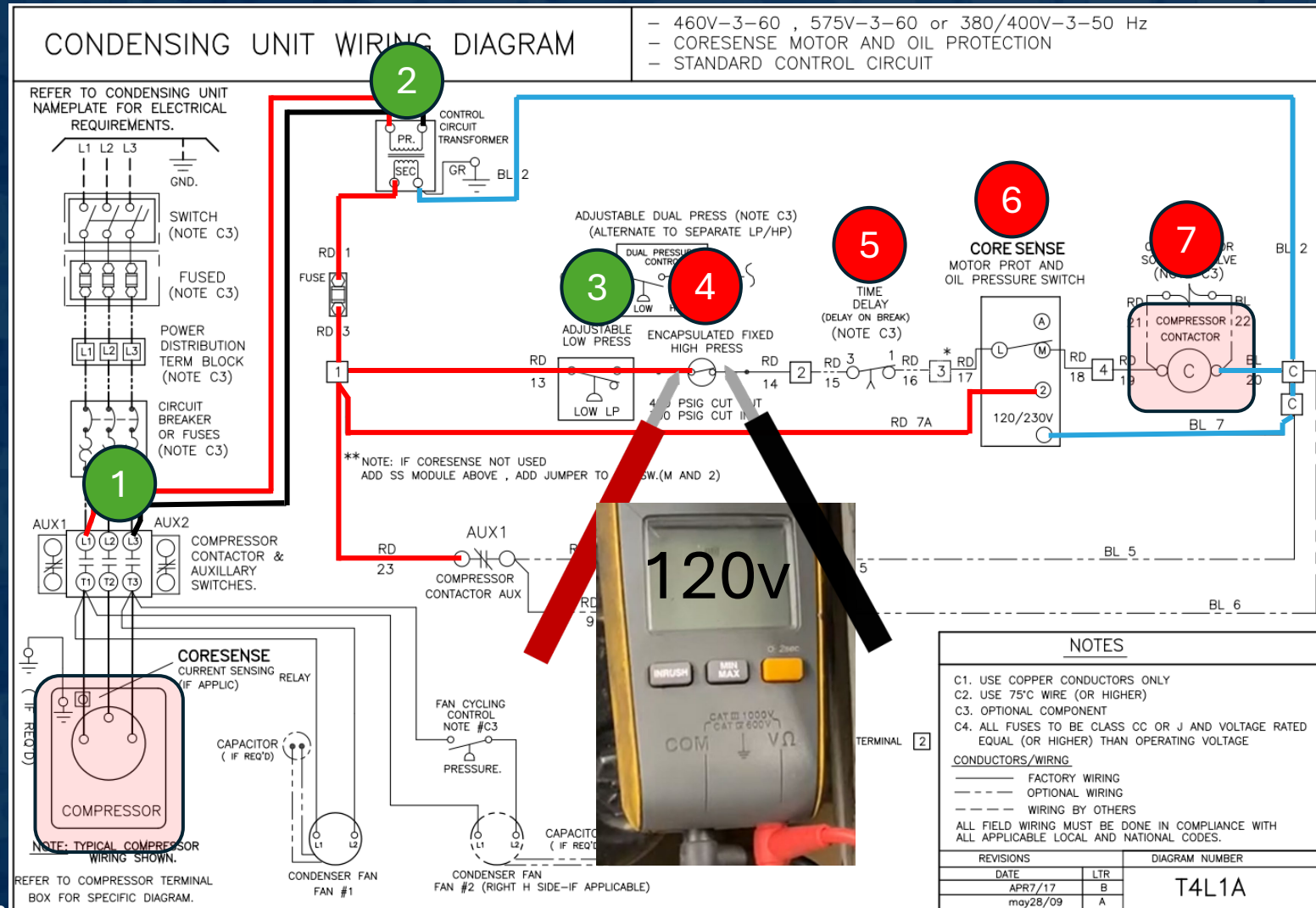



Differential pressure plus time

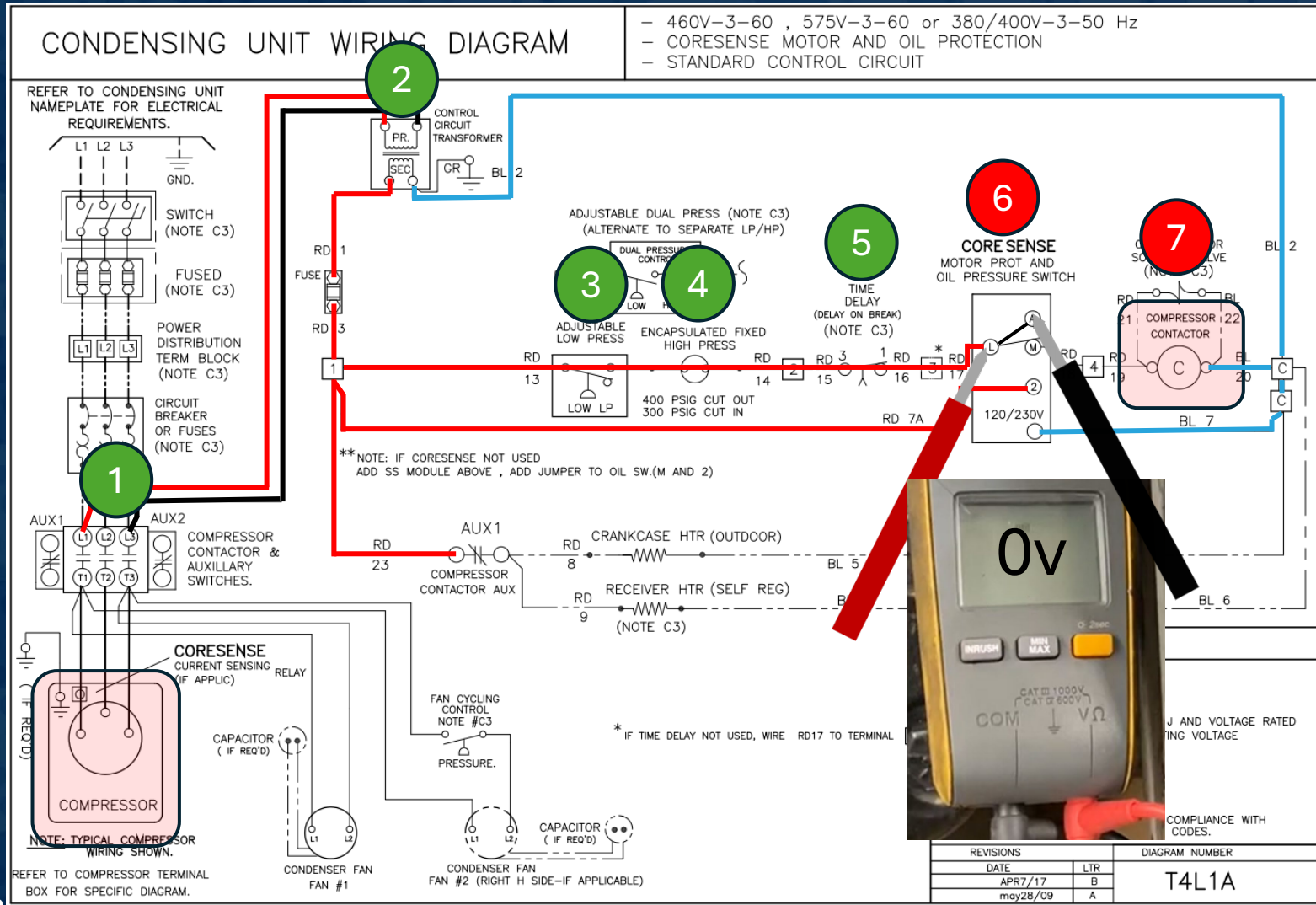



Protection with consequences

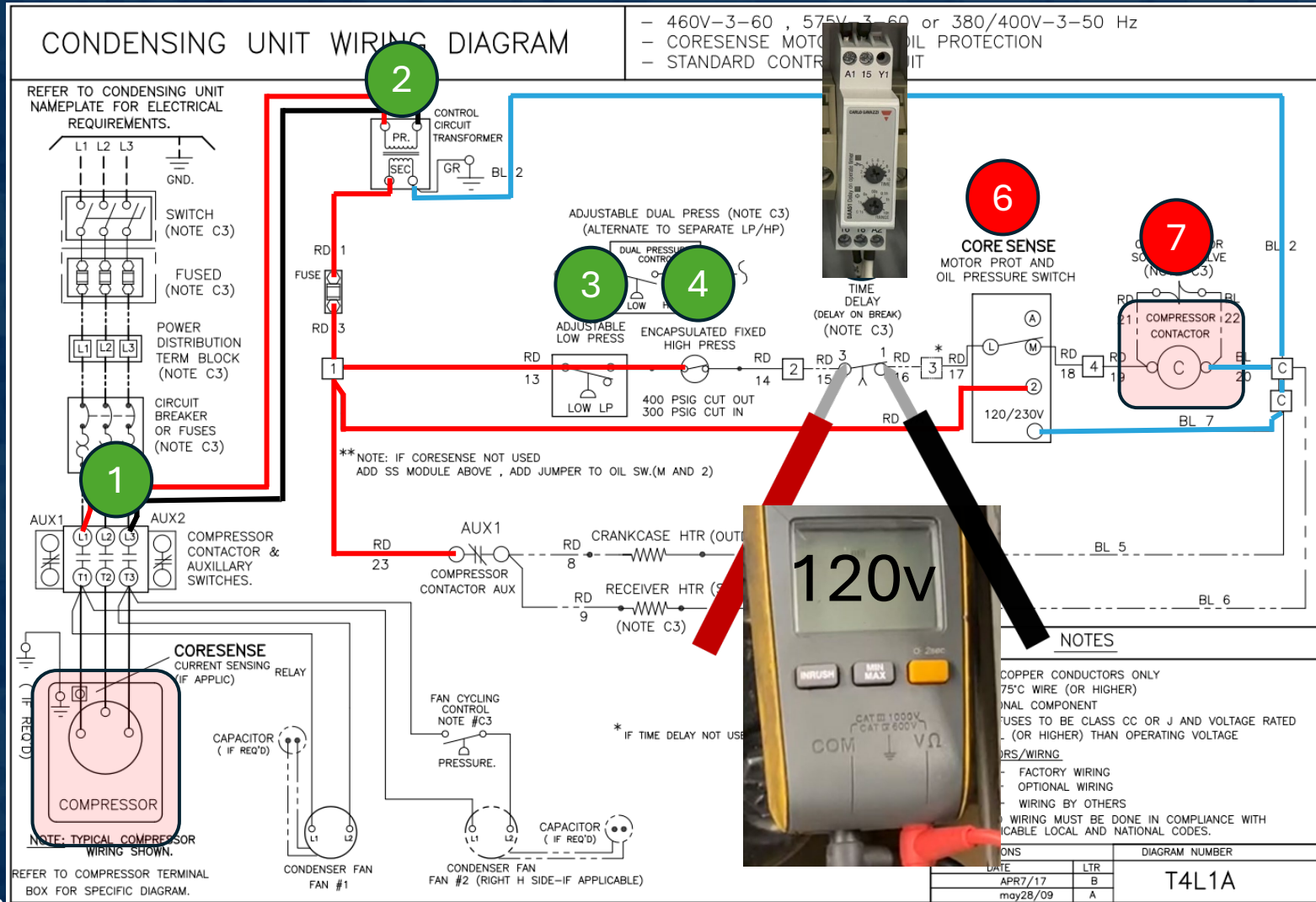



The gatekeeper

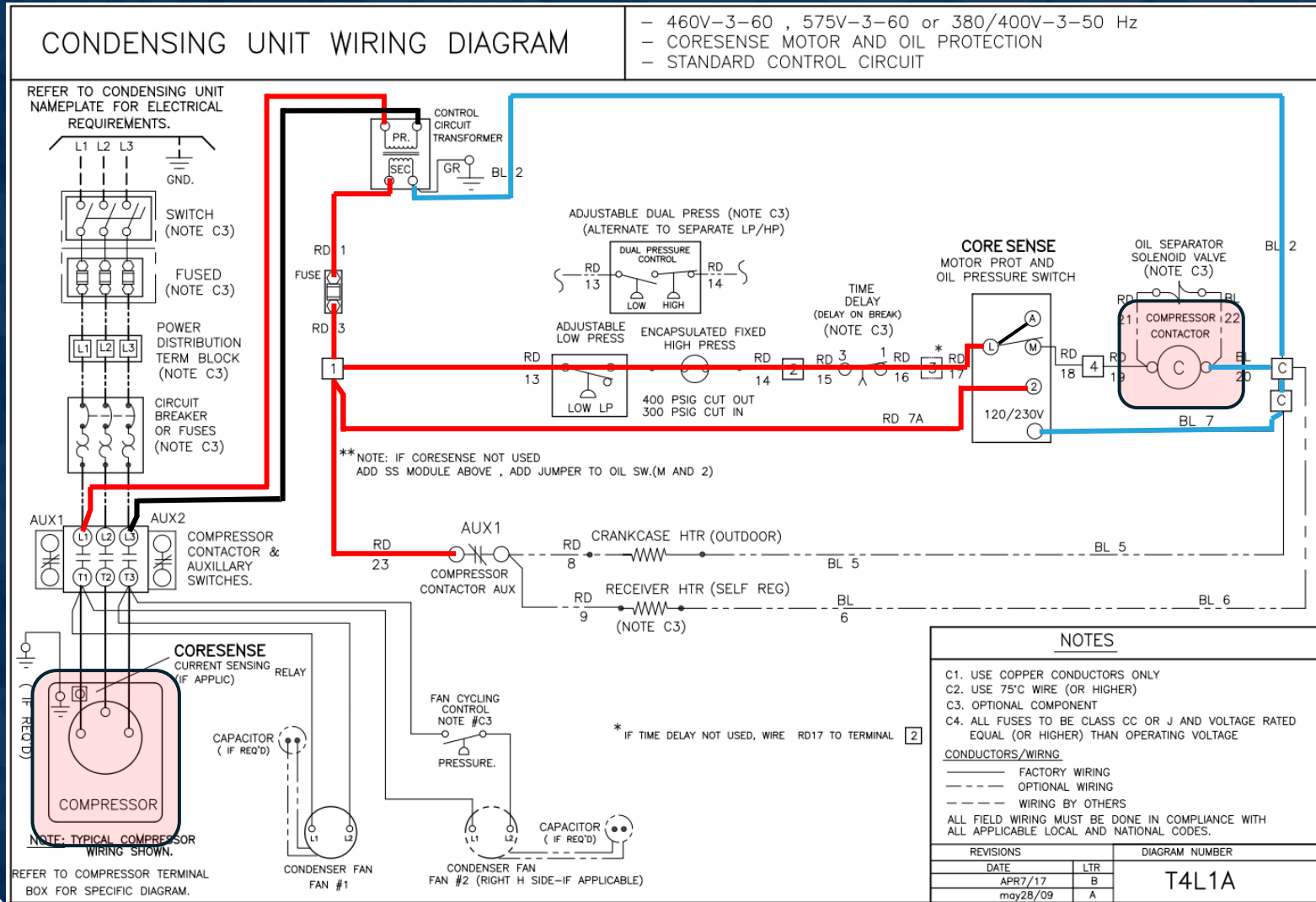



Measure across the coil

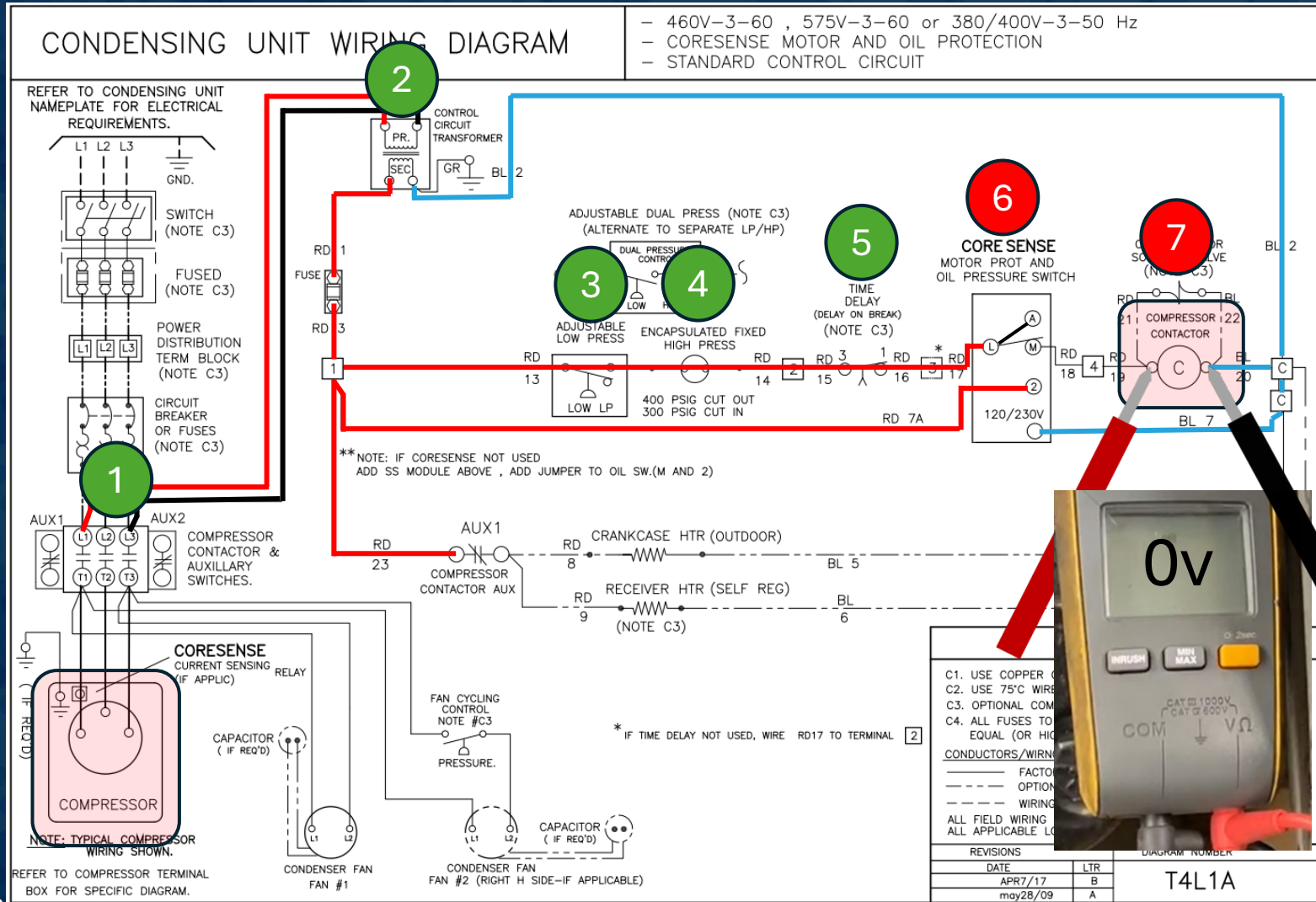



Line power doesn't equal operation

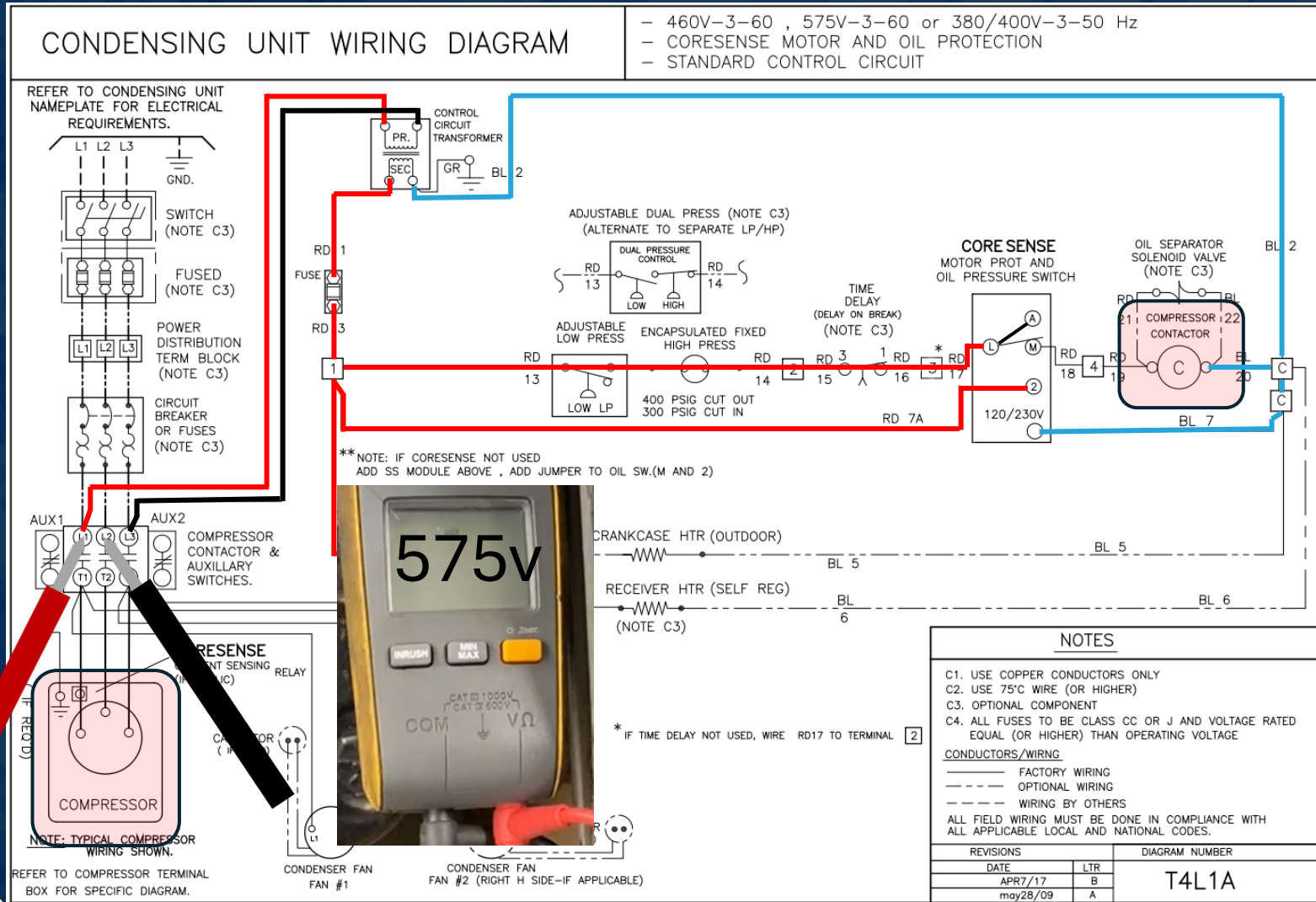



Visualize your measurement

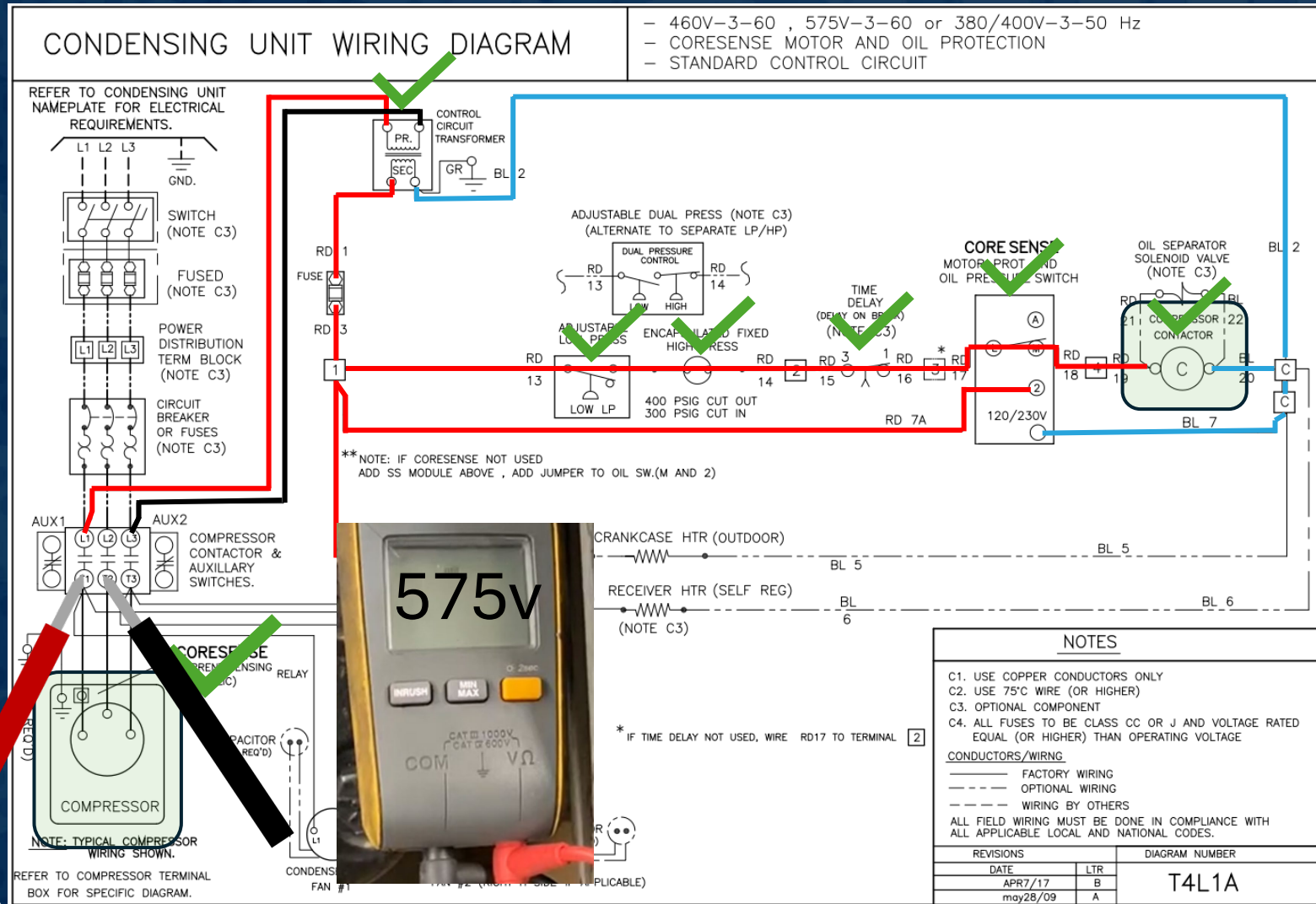

Everything looks normal

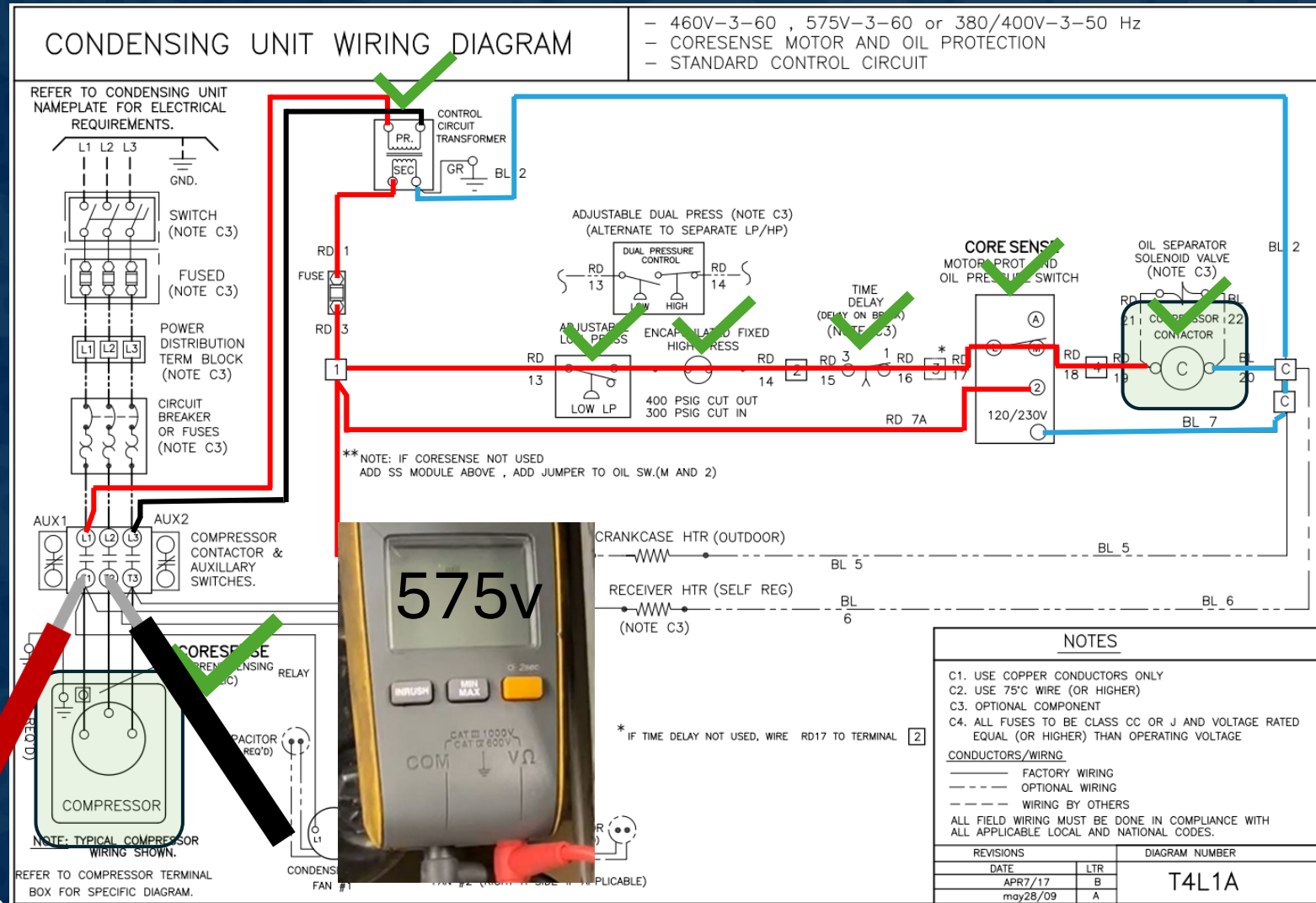

120 seconds later the circuit tells the truth

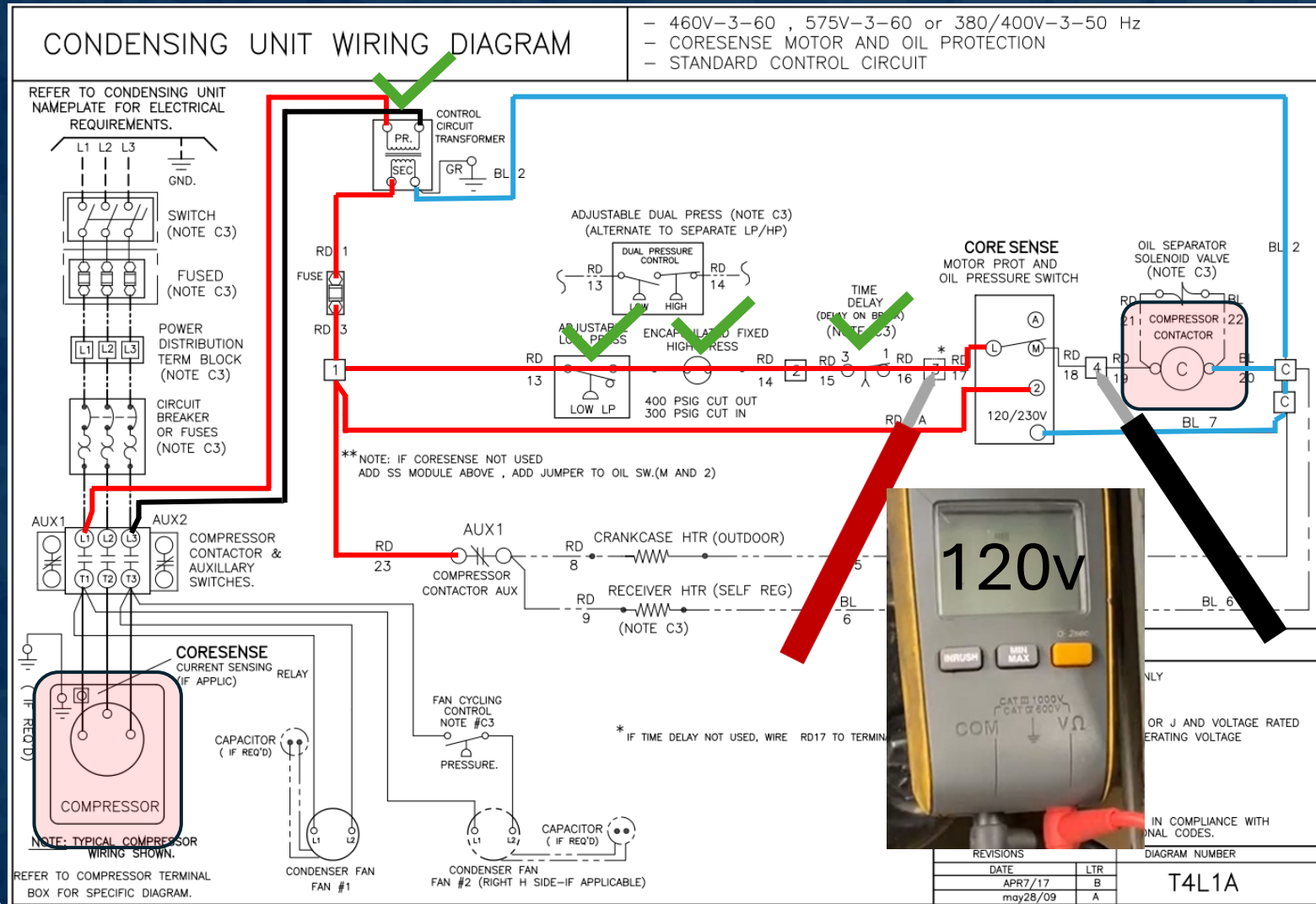



Commonly misunderstood

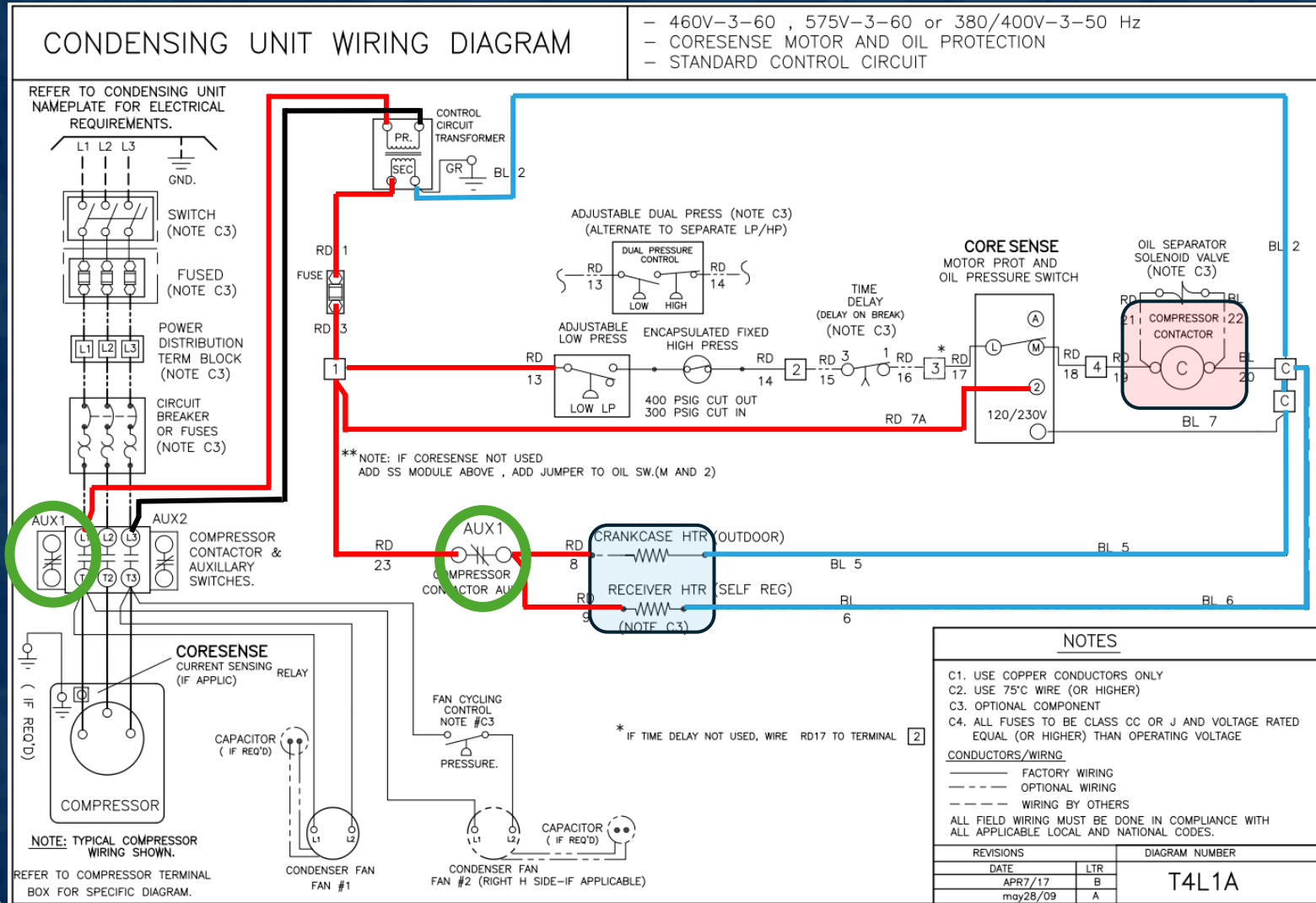

Pressure logic

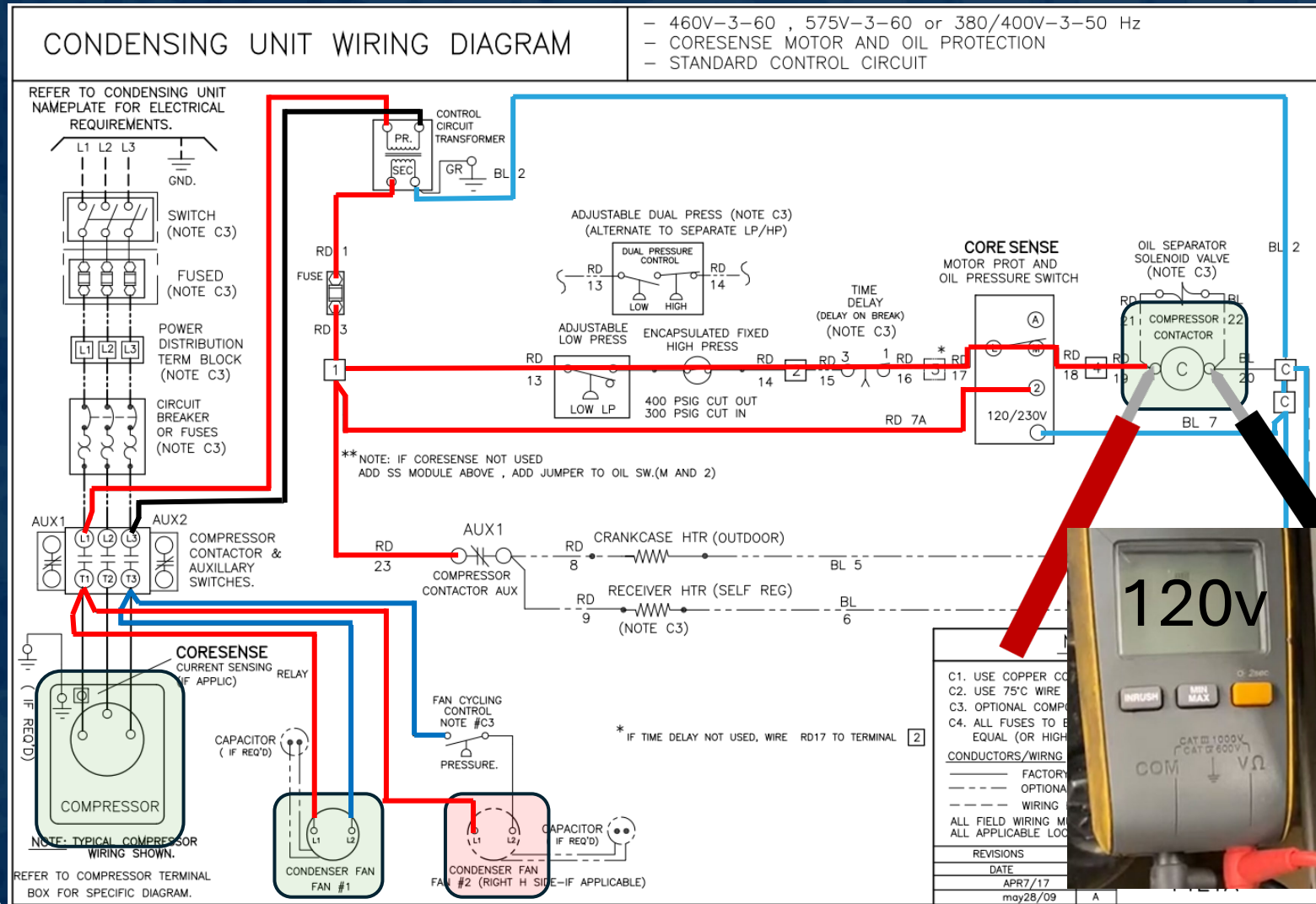

Multiple paths, same rules

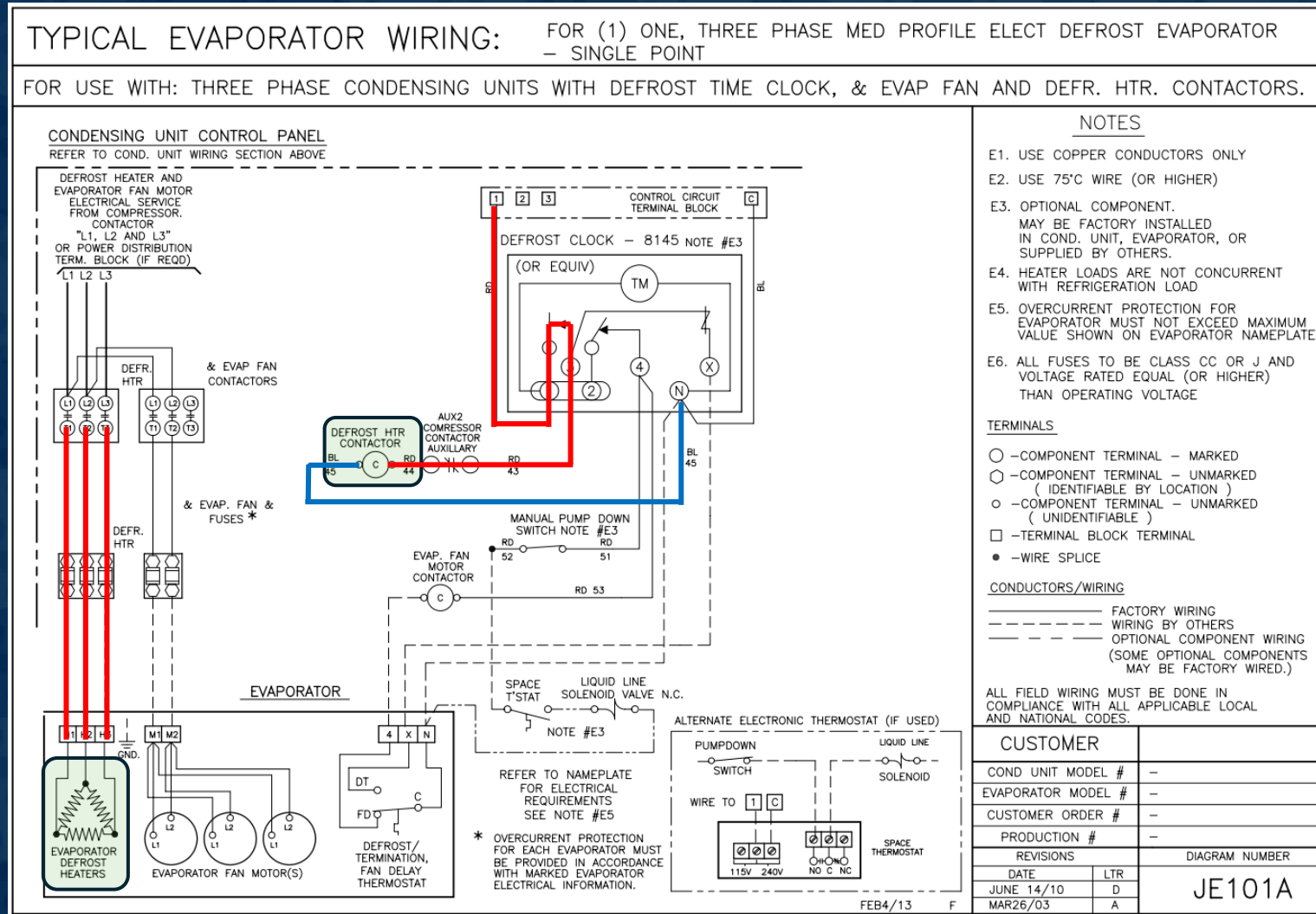

NOTES

- E1. USE COPPER CONDUCTORS ONLY
- E2. USE 75°C WIRE (OR HIGHER)
- E3. OPTIONAL COMPONENT. MAY BE FACTORY INSTALLED IN COND. UNIT, EVAPORATOR, OR SUPPLIED BY OTHERS.
- E4. HEATER LOADS ARE NOT CONCURRENT WITH REFRIGERATION LOAD
- E5. OVERCURRENT PROTECTION FOR EVAPORATOR MUST NOT EXCEED MAXIMUM VALUE SHOWN ON EVAPORATOR NAMEPLATE.
- E6. ALL FUSES TO BE CLASS CC OR J AND VOLTAGE RATED EQUAL (OR HIGHER) THAN OPERATING VOLTAGE

TERMINALS

- - COMPONENT TERMINAL - MARKED
- - COMPONENT TERMINAL - UNMARKED (IDENTIFIABLE BY LOCATION)
- - COMPONENT TERMINAL - UNMARKED (UNIDENTIFIABLE)
- - TERMINAL BLOCK TERMINAL
- - WIRE SPLICE

CONDUCTORS/WIRING

- FACTORY WIRING
- - - WIRING BY OTHERS
- · - · - OPTIONAL COMPONENT WIRING (SOME OPTIONAL COMPONENTS MAY BE FACTORY WIRED.)

ALL FIELD WIRING MUST BE DONE IN COMPLIANCE WITH ALL APPLICABLE LOCAL AND NATIONAL CODES.

CUSTOMER	
COND UNIT MODEL #	-
EVAPORATOR MODEL #	-
CUSTOMER ORDER #	-
PRODUCTION #	-
REVISIONS	DIAGRAM NUMBER
DATE	LTR
JUNE 14/10	D
MAR26/03	A
JE101A	

Read the notes

* IF OIL SWITCH NOT REQD, WIRE RD19 TO TERMINAL 3

* * IF TIMER NOT USED, WIRE RD17 TO TERMINAL 2

IF OIL SWITCH AND TIME DELAY NOT REQUIRED, WIRE RD19 TO TERMINAL 2

NOTES

- C1. USE COPPER CONDUCTORS ONLY
- C2. USE 75°C WIRE (OR HIGHER)
- C3. OPTIONAL COMPONENT
- C4. ALL FUSES TO BE CLASS CC OR J AND VOLTAGE RATED EQUAL (OR HIGHER) THAN OPERATING VOLTAGE

CONDUCTORS/WIRING

- FACTORY WIRING
- - - - - OPTIONAL WIRING
- - - - - WIRING BY OTHERS

ALL FIELD WIRING MUST BE DONE IN COMPLIANCE WITH ALL APPLICABLE LOCAL AND NATIONAL CODES.

Jumping safeties

Dangerous Shortcut



Normal means unpowered

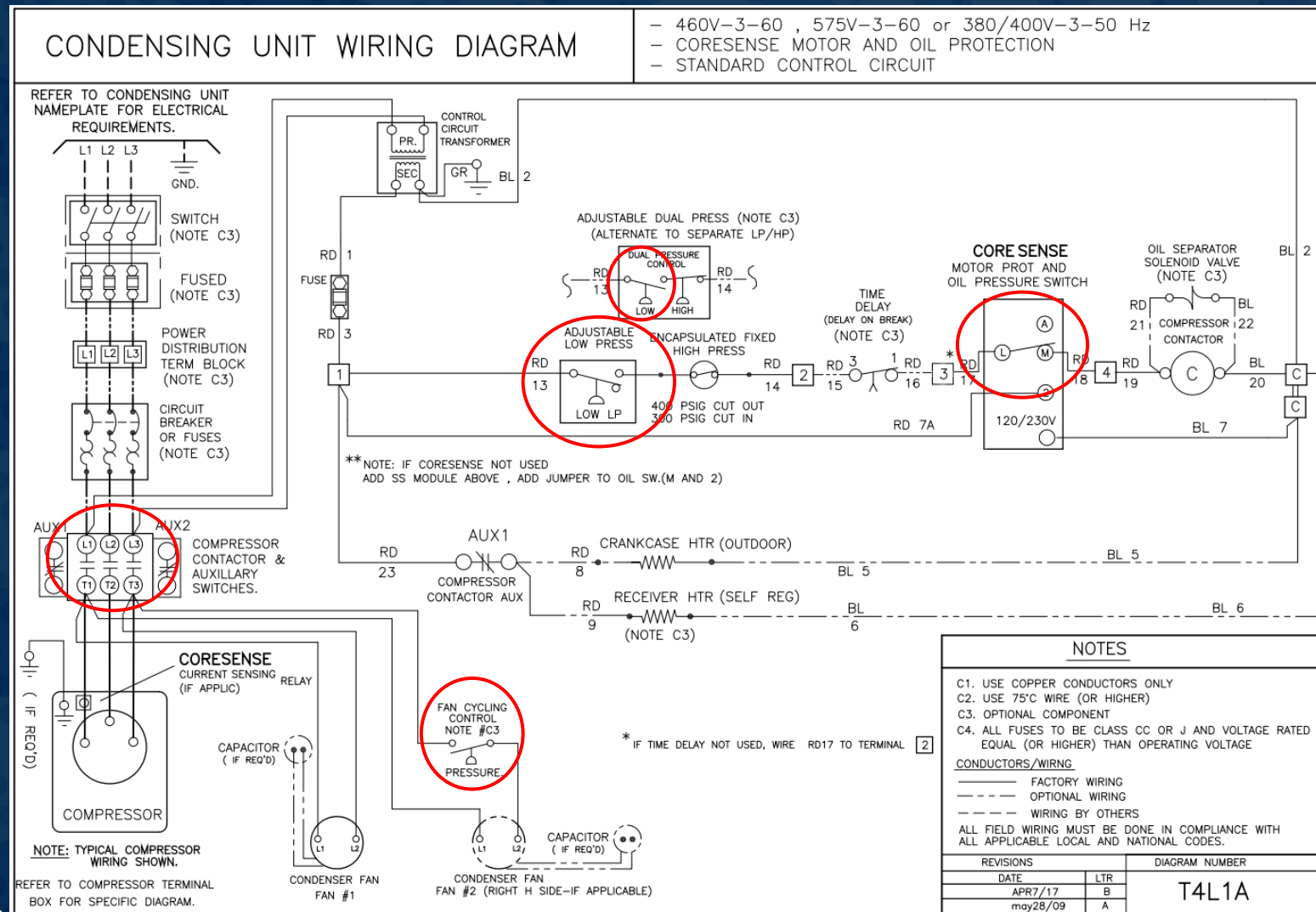

Smart Readings Beat More Readings

Think before measuring

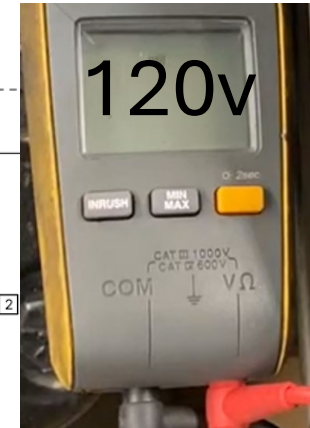
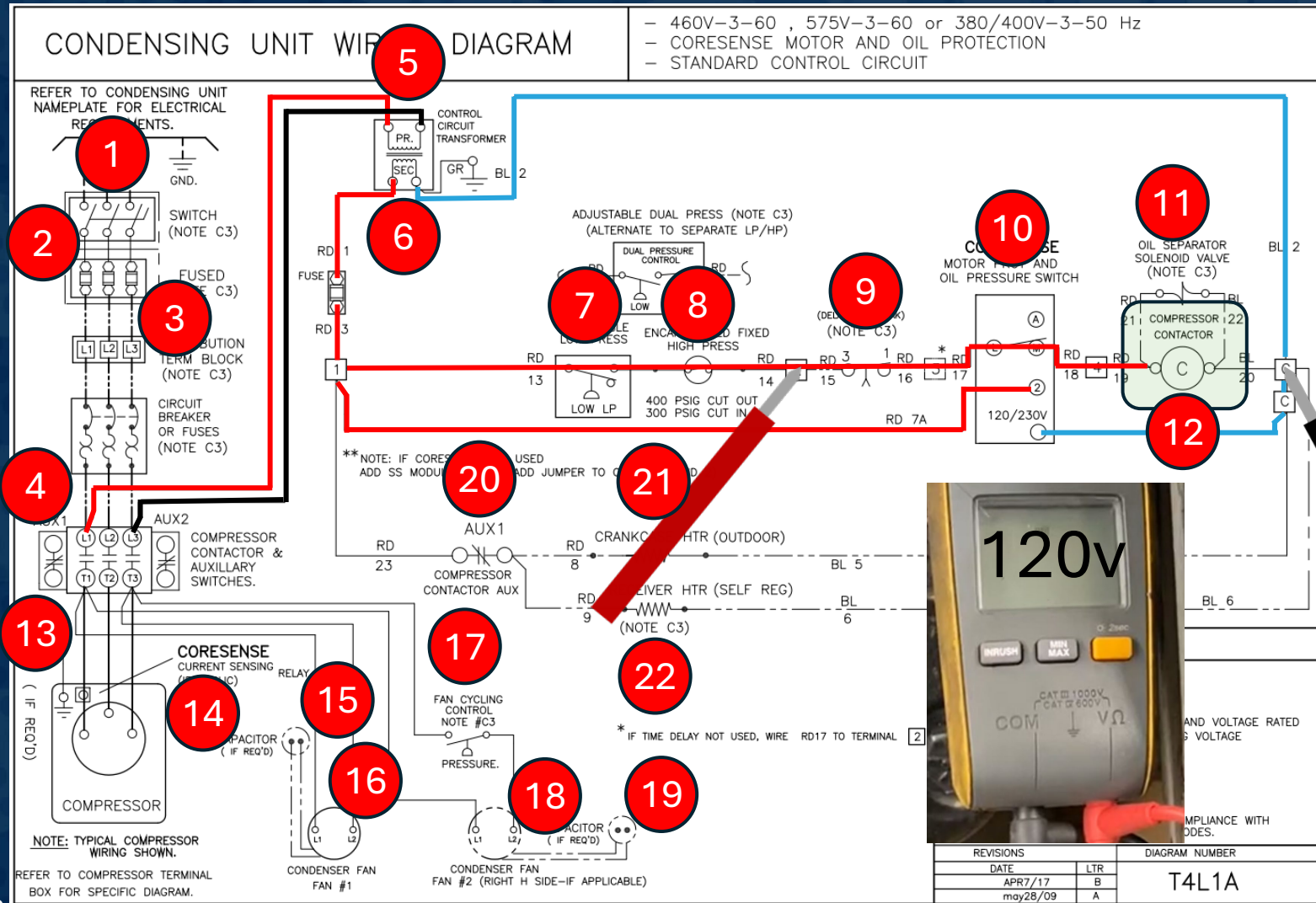

REVISIONS	DATE	LTR	DIAGRAM NUMBER
	APR7/17	B	T4L1A
	may28/09	A	

A repeatable method





Find its power source

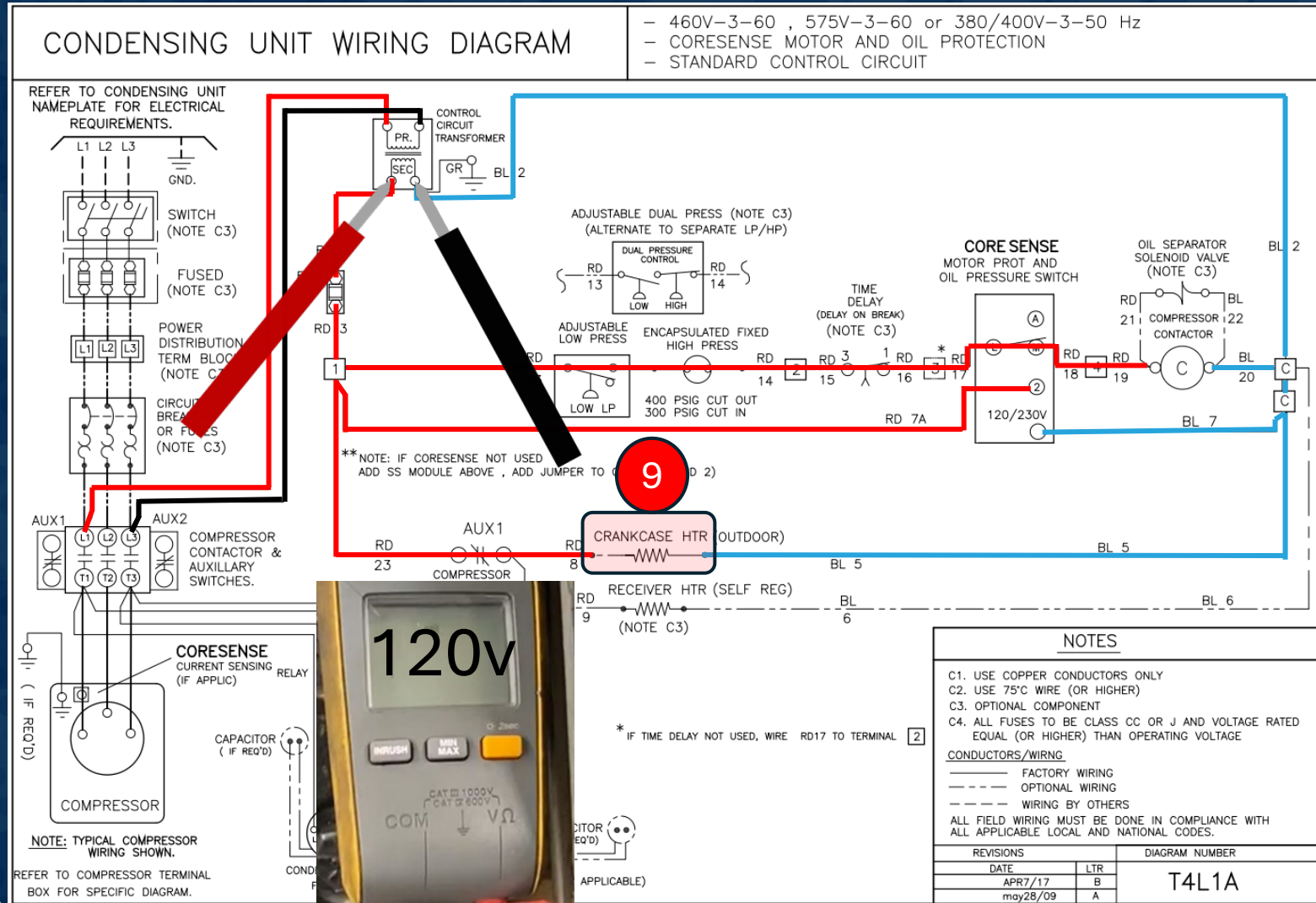



Measure across components

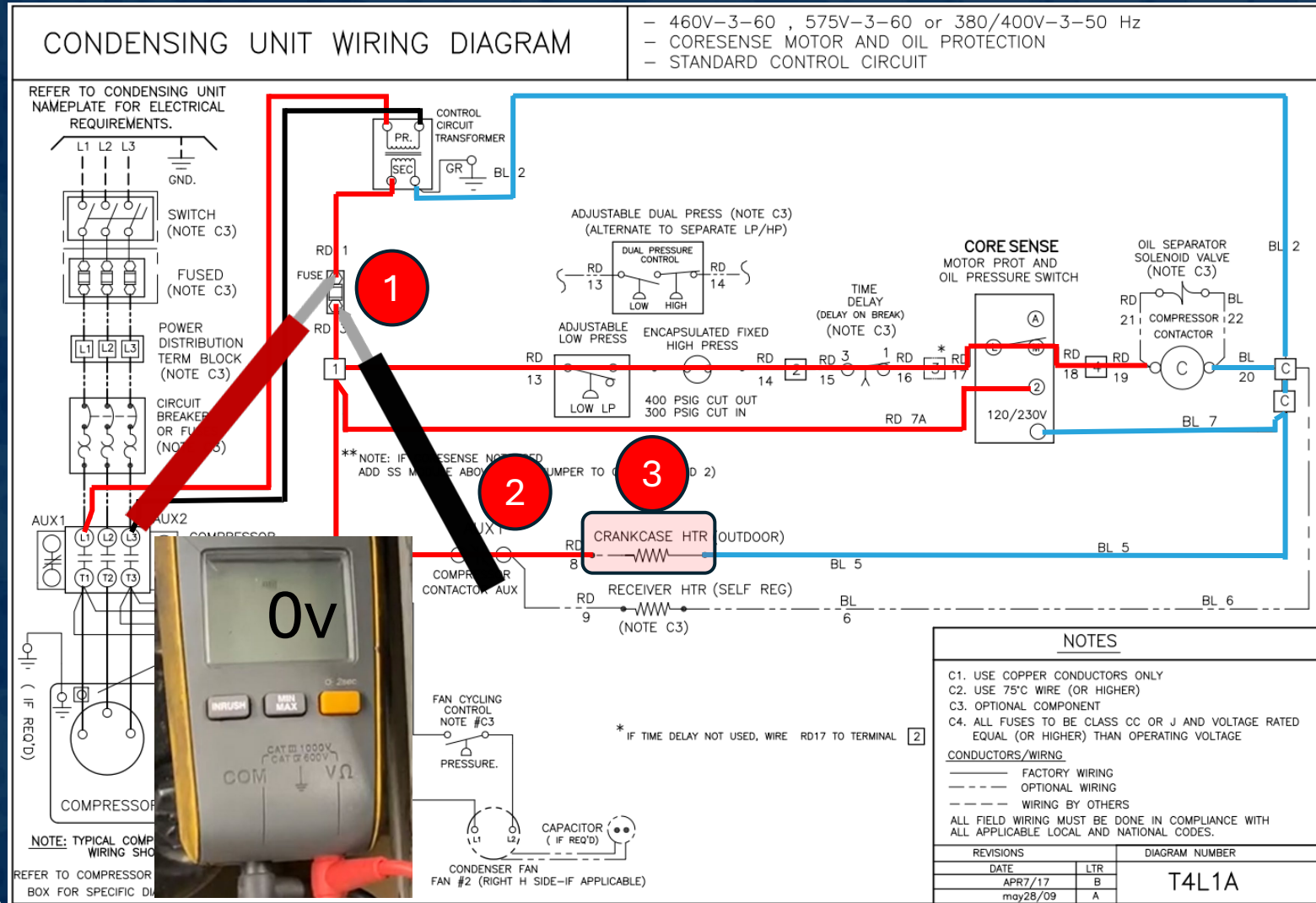



Follow the series path

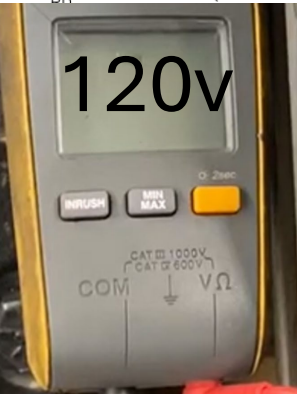
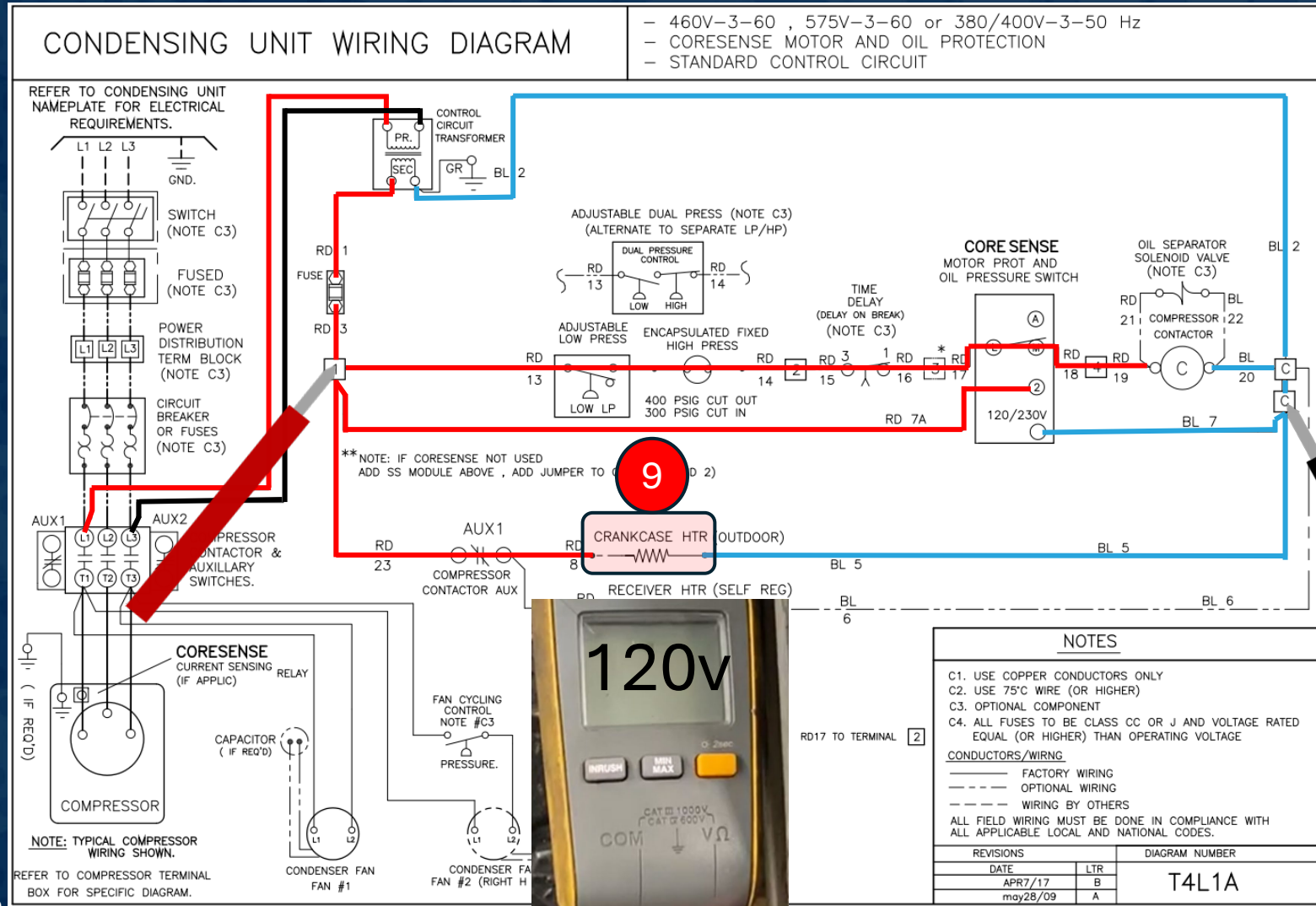



Find voltage drop, short or open circuit

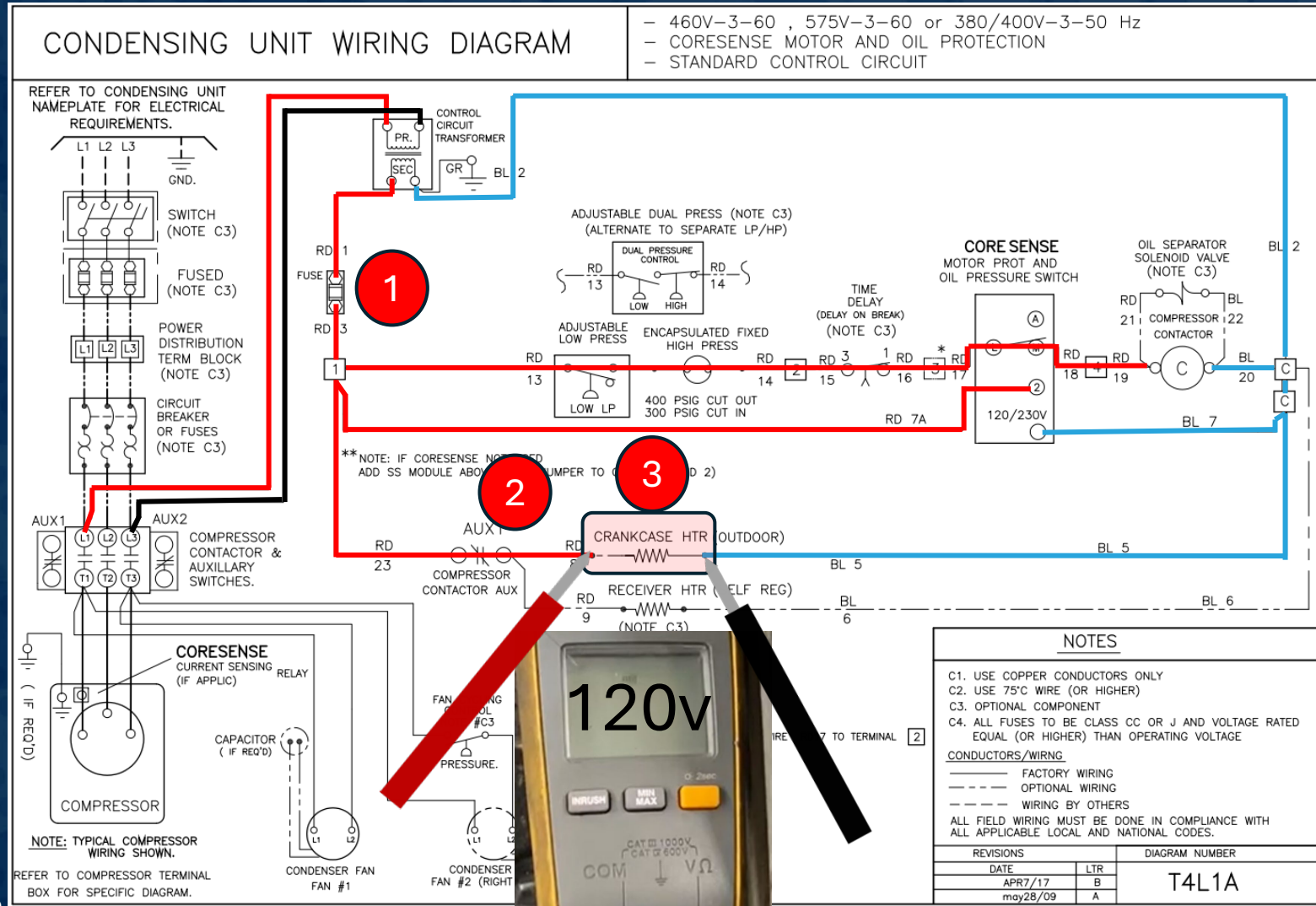



Prove the failure

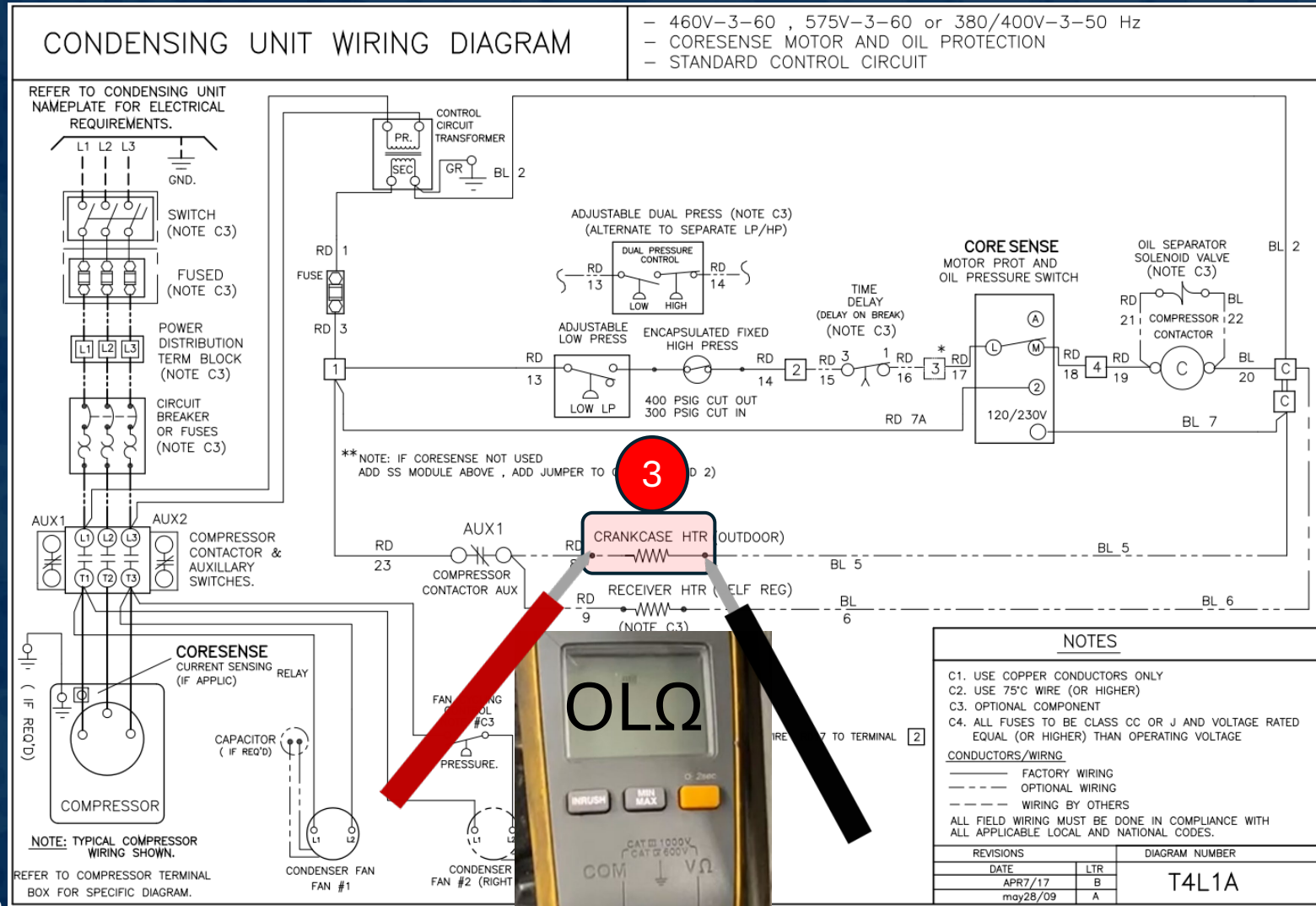

Electricity only does what the circuit allows

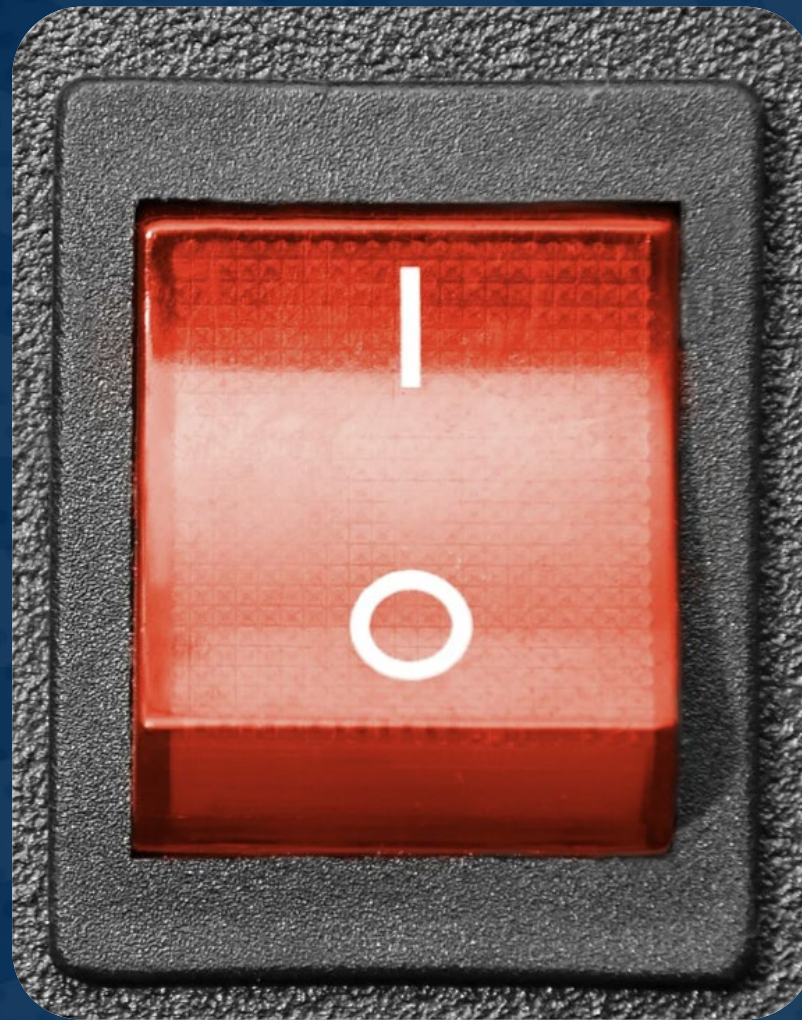

Slow down, prove it, stop guessing

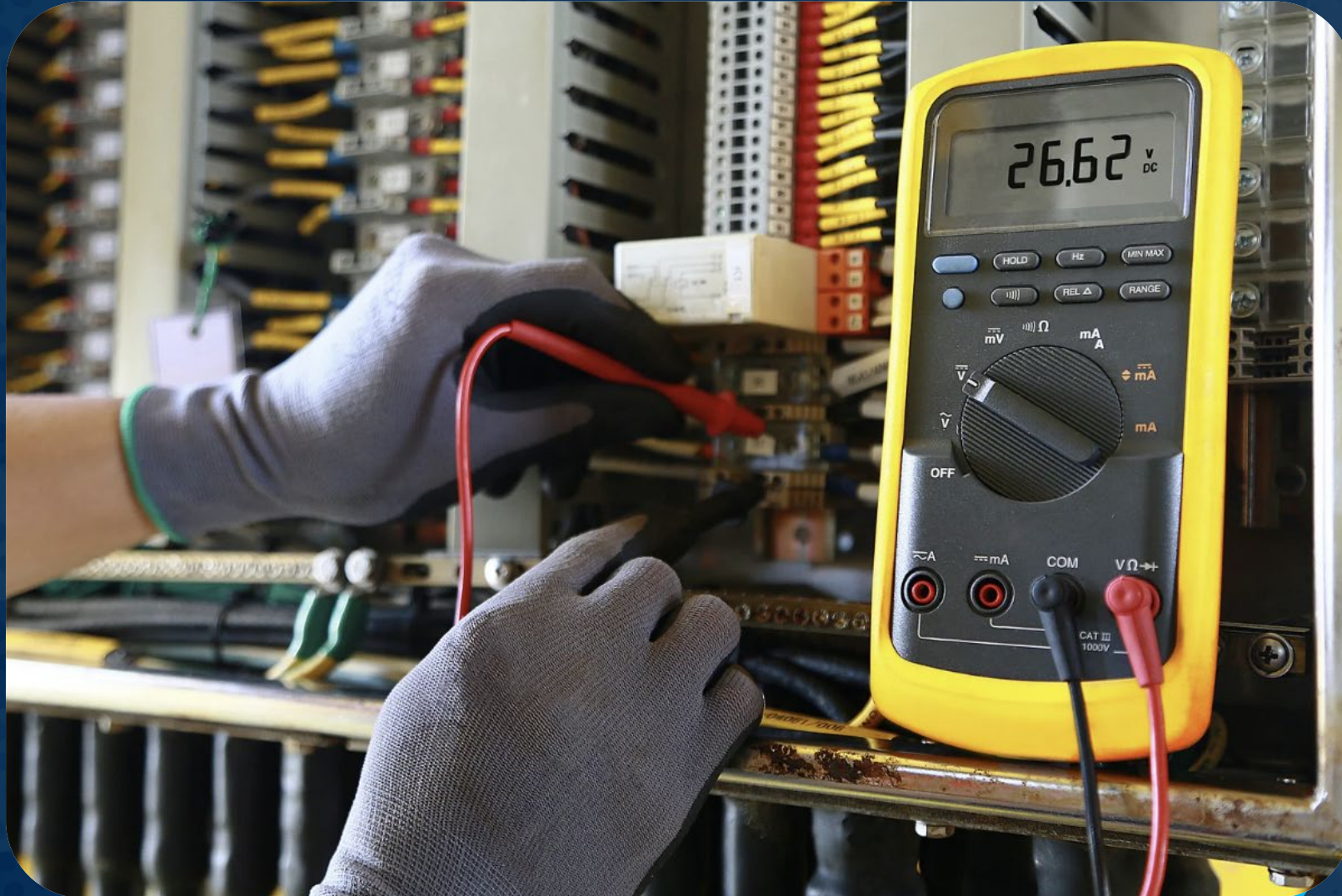

refrigerationmentor.com/ets

REFRIGERATION
MENTOR

WELCOME TO

Understanding Electrical Troubleshooting on Refrigeration Systems

LET'S GET A CONVERSATION GOING.

▶▶▶



Two Circuits Always Exist

Power and control circuits

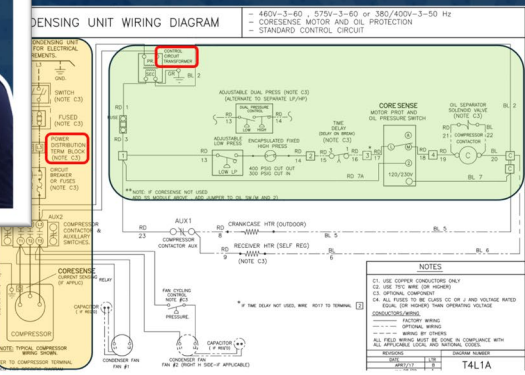

CONDENSING UNIT WIRING DIAGRAM - 460V-3-60, 575V-3-60 or 380/400V-3-50 Hz
- CORESENSE MOTOR AND OIL PROTECTION
- STANDARD CONTROL CIRCUIT

NOTES:
1. USE COPPER CONDUCTORS ONLY.
2. USE THE WIRE SIZE SHOWN.
3. ALL WIRES TO BE CLASS C0 OR J AND VOLTAGE RATED.
4. ALL WIRES TO BE IDENTIFIED BY NUMBER OR LETTER.
5. ALL WIRES TO BE IDENTIFIED BY NUMBER OR LETTER.
6. ALL WIRES TO BE IDENTIFIED BY NUMBER OR LETTER.
7. ALL WIRES TO BE IDENTIFIED BY NUMBER OR LETTER.
8. ALL WIRES TO BE IDENTIFIED BY NUMBER OR LETTER.
9. ALL WIRES TO BE IDENTIFIED BY NUMBER OR LETTER.
10. ALL WIRES TO BE IDENTIFIED BY NUMBER OR LETTER.

Divide and Conquer

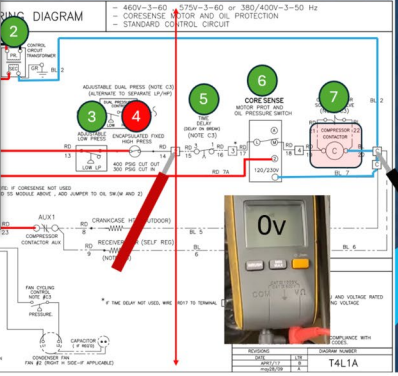

CONDENSING UNIT WIRING DIAGRAM - 460V-3-60, 575V-3-60 or 380/400V-3-50 Hz
- CORESENSE MOTOR AND OIL PROTECTION
- STANDARD CONTROL CIRCUIT

2. FAN MOTOR
3. FAN MOTOR
4. FAN MOTOR
5. FAN MOTOR
6. CORESENSE MOTOR
7. CORESENSE MOTOR

0v



REFRIGERATION
MENTOR

Free Electrical Troubleshooting Training

ELECTRICAL TROUBLESHOOTING FREE WEBINAR

REGISTER FOR FREE!

Learn how to quickly diagnose and fix common electrical issues in refrigeration systems.

Name:

Email:

Register Now!



SCAN HERE



Master the Electrical Side of Refrigeration

THANK YOU!